

Rotary Joint | BN 636602C0005

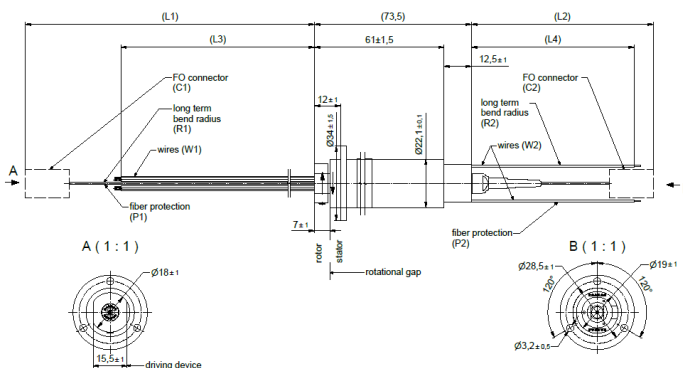

image similar



all dimensions in mm

Fiber optic characteristics

Channels	1 CH	
Channel designation	1	
Fiber type	Singlemode E9/125	
Side	Rotor	Stator
FO connector (C1 / C2)	ST/UPC	ST/UPC
Fiber protection (P1 / P2)	900 µm buffer	900 µm buffer
Fiber length (L1 / L2)	500 ±150 mm	500 ±150 mm
Long term bending radius, min. (R1 / R2)	30 mm	30 mm
Wavelength	1310/1550 nm	
Average power rating, max.	200 mW / 23 dBm	
Return Loss, min.	20 dB	
Insertion loss, max.	3.5 dB	
Insertion loss variation with rotation, max.	1.5 dB	

SPINNER GmbH
 This document is proprietary to us.
 All rights reserved. Any use, transfer, or reproduction of this document
 or the know-how contained therein requires our express consent.

Rotary Joint | BN 636602C0005

Slip ring characteristics

Group designation		A
Number of channels		24
Number of paths per channel		1
Signal type		DC
Current,	DC nominal	1 A
Voltage	DC nominal	24 VDC
Side	Rotor	Stator
Wires (W1 / W2)	24x AWG26/19 PTFE	24x AWG26/19 PTFE
Connector	Flying leads, no connector	Flying leads, no connector
Cable length (L3 / L4)	300 \pm 100 mm	300 \pm 100 mm



Rotary Joint | BN 636602C0005

Mechanical characteristics

Rotating speed, max.	250 rpm
Life, min.	10 x 10 ⁶ revolutions
Torque (room temperature), max.	0.06 Nm @ rotation
Interface loads, max.	no loads allowed
Case material	Polycarbonate PCGF 30, copper alloy
Case surface finish	no finish
IP protection level	IP50 per EN 60529 (all interfaces connected with appropriate gaskets)
Weight, approx.	0.160 kg
Marking	laser engraving (SPINNER logo)

Environmental conditions

Operation	
Ambient temperature range	-20 °C to +80 °C
Relative humidity, max.	95% (non-condensing)
Storage	
Ambient temperature range	-20 °C to +80 °C
Relative humidity, max.	95% (non-condensing)

Applicable documents

Technical information	“Rotary Joints – Glossary”, technical document TD-00021, Spinner GmbH
Application note	“Handling of Optical Fibers and Fiber Optical Rotary Joints”, technical document TD-00283, Spinner GmbH

SPINNER GmbH
 This document is proprietary to us.
 All rights reserved. Any use, transfer, or reproduction of this document
 or the know-how contained therein requires our express consent.

Template Normal.dotm