

## Coaxial 3-way Splitter 694 - 3800 MHz

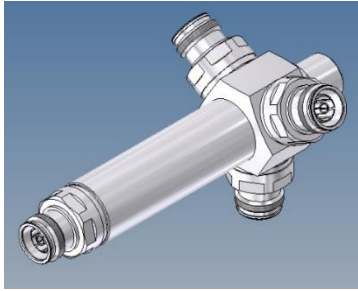

Picture not binding

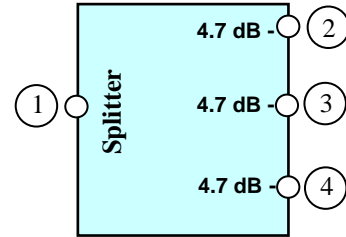

Block diagram

### Electrical characteristics

Part number	BN 818267
Splitting ratio	1: 0.33: 0.33: 0.33
Frequency range	694 - 3800 MHz
Insertion loss	≤ 5.0 dB
VSWR	≤ 1.2 (Port 1)
Output difference	≤ 0.3 dB
Phase difference	≤ 3°
Power Rating	≤ 500 W (CW)
DC-by-pass	N/A
Passive intermodulation (IM3), 3rd order @ 2 x 20W	-160 dBc max. / -165 dBc typ.
Impedance	50 Ohm

### Mechanical characteristics

Connectors	4.3-10 female
Dimensions, approx.	89 x 77 x 167 mm (Width x Height x Depth)
Weight, approx.	0.58 kg
Color	No painting
Wall / Mast mounting	to be ordered separately under BN B07691

### Environmental conditions

Class. of environmental conditions	ETSI EN 300019-1-1 Class 1.2 ETSI EN 300019-1-2 Class 2.3 ETSI EN 300019-1-3 Class 4.1E
Degree of protection	IP 68
Operation Ambient temperature range	-25 °C to +55 °C
Storage Ambient temperature range	-40 °C to +85 °C
Relative humidity, max.	95% (non-condensing)

This document is proprietary to us. All rights reserved. Any use, transfer, or reproduction of this document or the know-how contained therein requires our express consent.

Template TD-00002Y

**Outline** (all dimensions in millimeter)

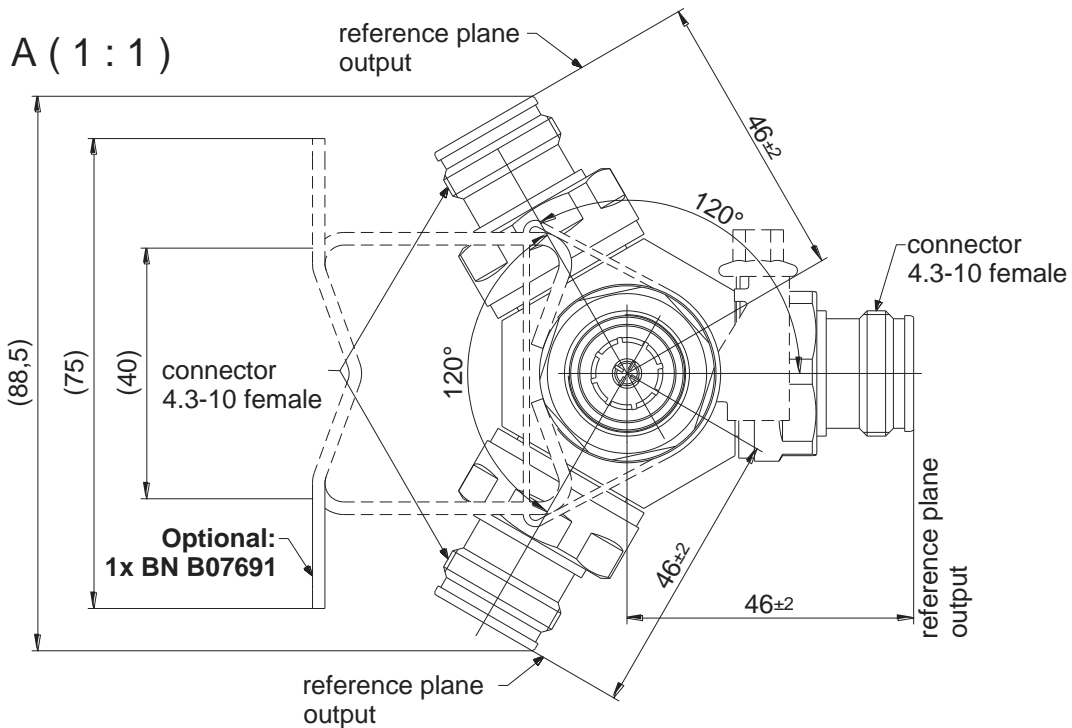
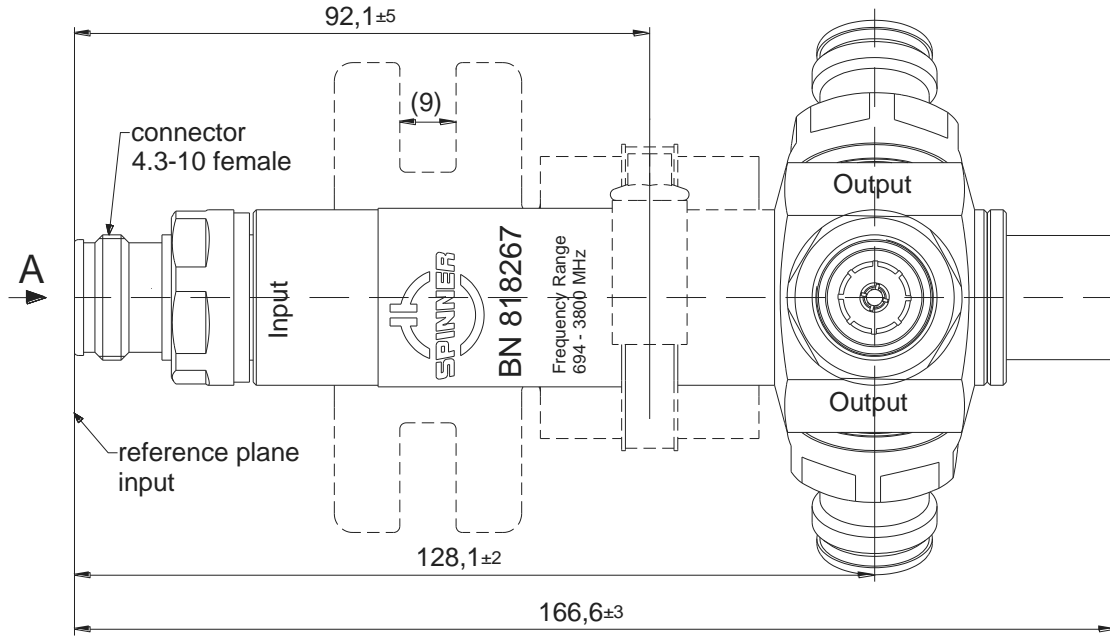

**Standard:**  
4.3-10 female (50 ohms): IEC 61169-54

modifications reserved!

SPINNER GmbH  
This document is proprietary to us.  
All rights reserved. Any use, transfer, or reproduction of this document  
or the know-how contained therein requires our express consent.

Template TD-00002Y

Measurements:

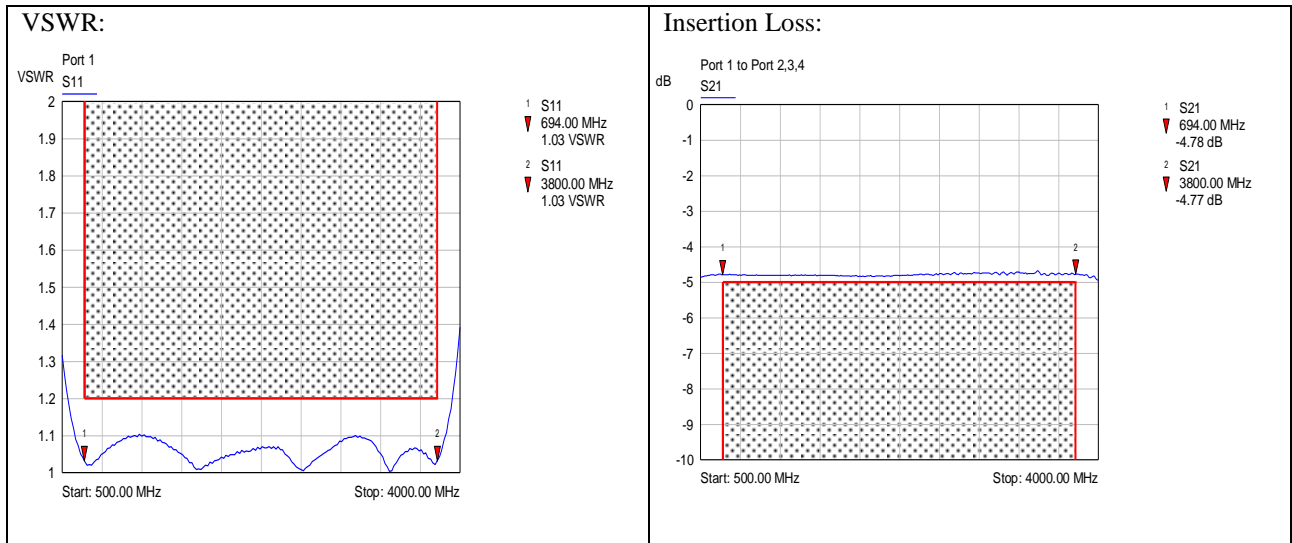

Signal splitting ratios (approximate values, for information only):

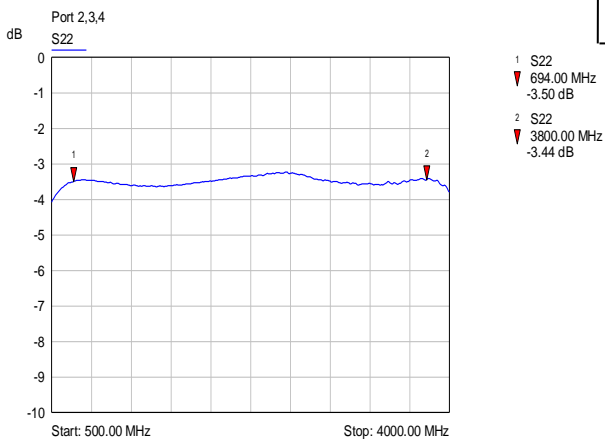
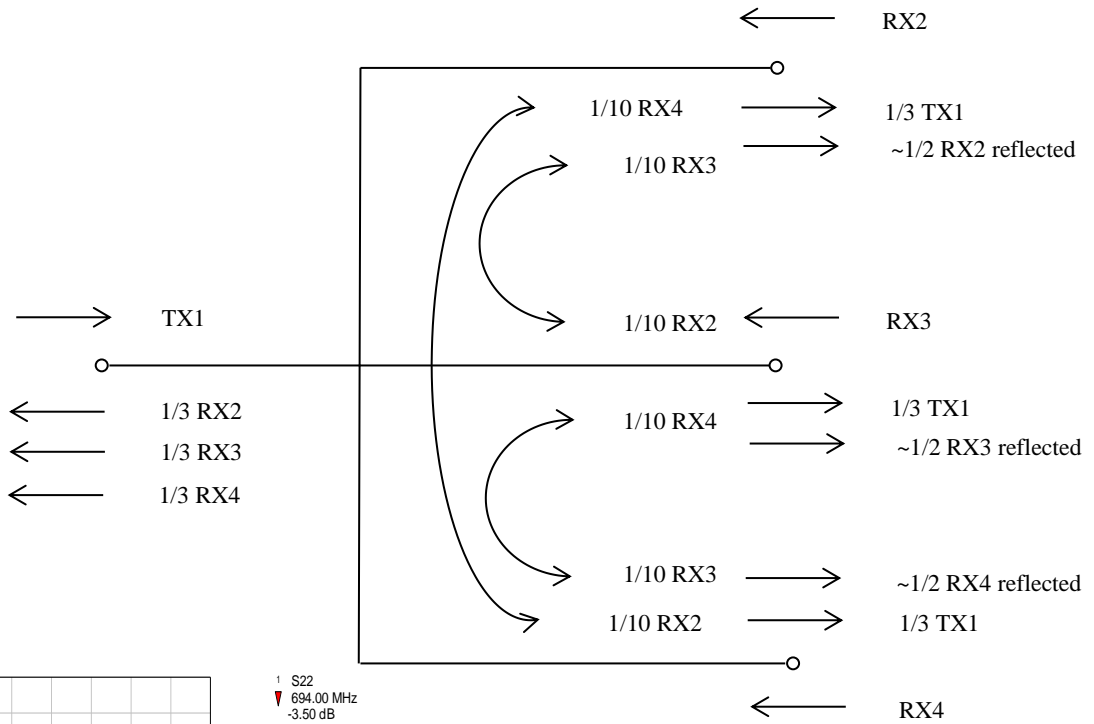

This document is proprietary to us. All rights reserved. Any use, transfer, or reproduction of this document or the know-how contained therein requires our express consent.

Template TD-00002Y