

# PLC Instructions 23587A

## SPINNER SamrtLoad

### PLC Programming and read out



Before you start, ensure to read and understand the section safety messages and in particular chapter 1 "Safety" of the product manual supplied with this product. Only electrically skilled persons may open the control box of SPINNER dummy loads to operate the PLC in accordance with the national safety and accident prevention regulations.

Failure to observe could result in death or serious injury.

### Preparing the PLC

Switch on your SmartLoad and wait until all devices have been running through their boot sequences. The green light on the front panel shows you, that the system is ready. Open the door of the electric control box with the delivered key.

The initial screen is displayed (exemplary):

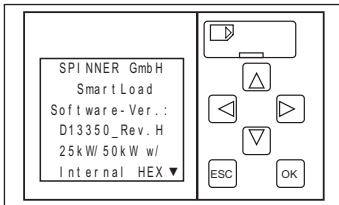

### PLC description

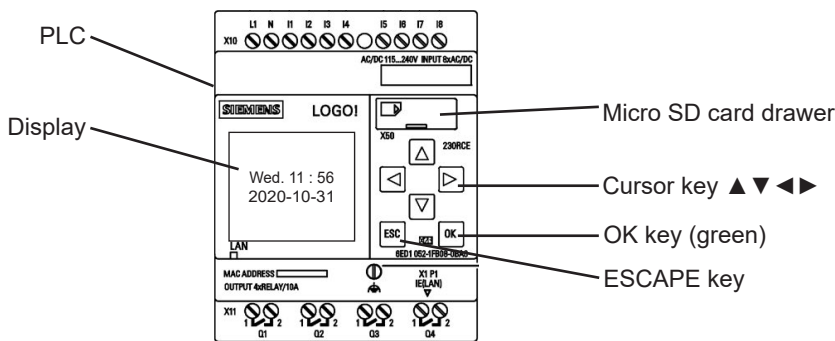

### PLC clock time setting

To ensure proper longterm operation of the coolant pump, the PLC activates autonomous maintenance cycles daily for the duration of a few minutes. If there is a power outage of the PLC for more than approx. 20 days, on restarting, the internal clock is back in the status that it was in before the power outage. For correct execution, set the PLC clock as follows:

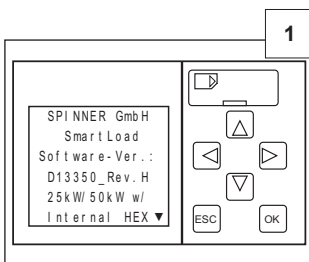

1 Press Key ▼ until the date screen is displayed.

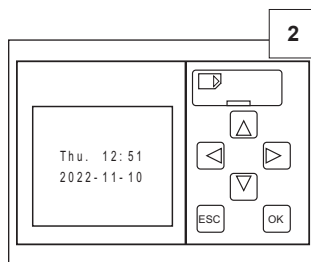

2 Press ESC.

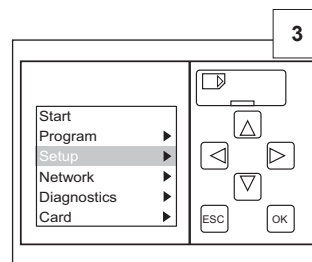

3 Select "Setup" (Key ▼ or ▲) and press OK.

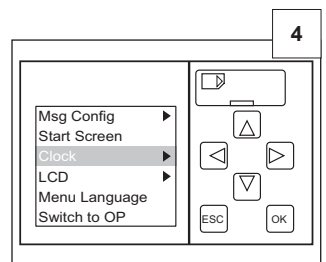

4 Select "Clock" (Key ▼ or ▲) and press OK.

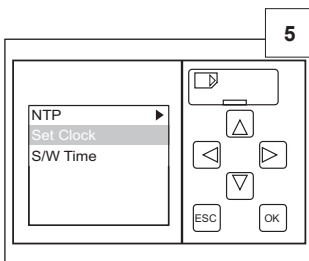

5 Select "Set Clock" (Key ▼ or ▲) and press OK.

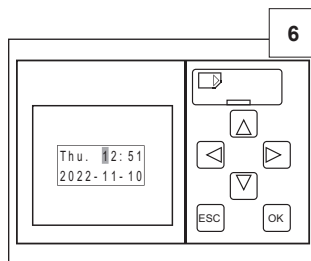

6 Move the cursor onto required position (Key ◀ or ▶) and modify the value (Key ▼ or ▲) to set time and date.

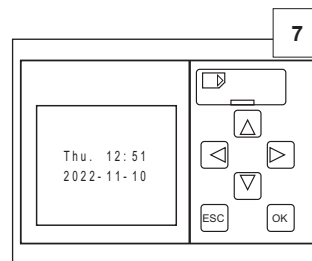

7 Press ESC 4x and then press ▲ key several times to return to the initial screen.

## SPINNER SamrtLoad

PLC Programming and read out

### Read out Temperature Values and Service Information

The PLC provides additional information about the operating status. The ▼ ▲ keys can be used to call up additional screens:

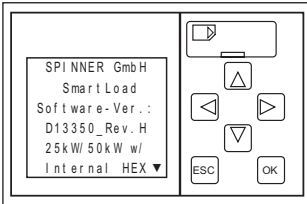

Initial screen with software number and revision. (exemplary)

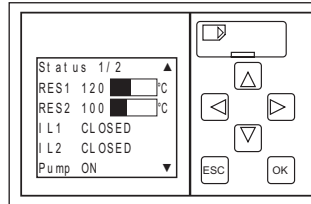

Resistor temperature values of SmartLoads with two resistors.  
Interlock loop status.  
Pump status (on or off).

and

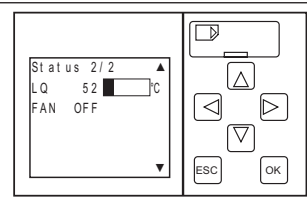

Coolant temperature value of SmartLoads with two resistors.  
Fan status (on or off).

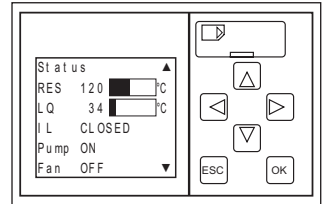

Temperature values of SmartLoads with one resistor.  
Interlock loop status.  
Pump and fan status (on or off).

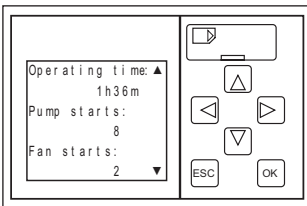

Overall operating time as well as pump and fan starts.

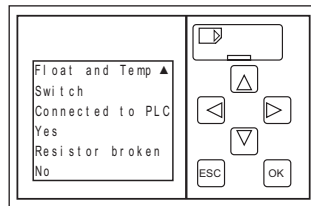

Informs whether a float switch is integrated in the PLC and whether a leakage has occurred.

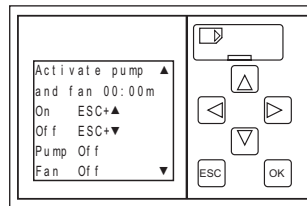

Indicates whether the pump and fan have been activated manually.

These screens appear automatically. The display changes from a white background to an orange background:

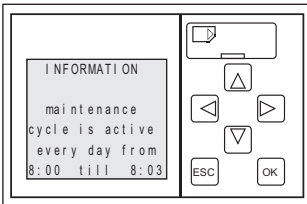

Maintenance cycle information disappears automatically when the cycle is finished.

This screen only appears for SmartLoads with external heat exchanger.

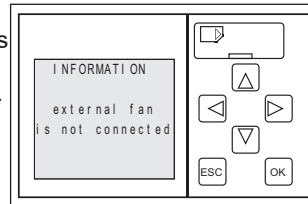

"Fan not connected" information disappears as soon as the fan is connected.

When an error occurs, one of the following screens is displayed. The display changes from a white background to a red background. If several errors occur, the individual information can be called up using the ▼ ▲ keys.

By pressing the pump button on the back of the control box, clears all error messages except the master alarm message.

To clear the master alarm message, the pump button must be pressed for 5 seconds:

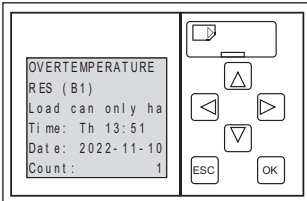

Overtemperature at the resistor for SmartLoads with one resistor.

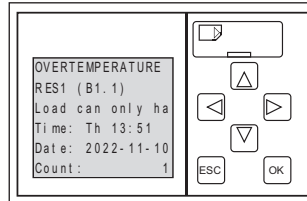

Overtemperature at the resistor 1 for SmartLoads with two resistors.

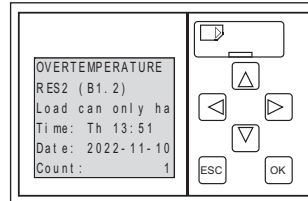

Overtemperature at the resistor 2 for SmartLoads with two resistors.

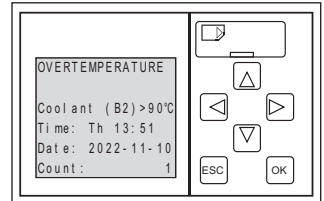

Overtemperature of the coolant.

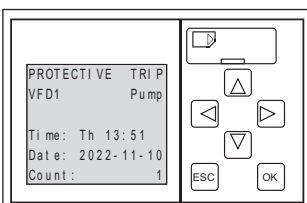

Motor protection of the pump has tripped.

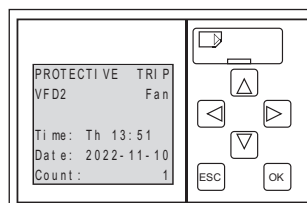

Motor protection of the fan has tripped.

# PLC Instructions 23587A

## SPINNER SamrtLoad

### PLC Programming and read out

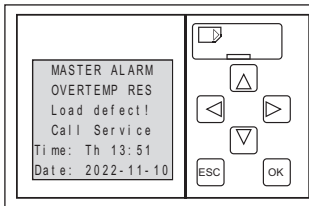

Multiple overtemperature events have occurred and there may be a defect in the resistor element.

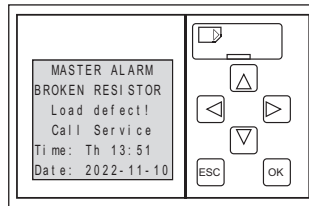

A leakage has occurred at the resistor element and there may be a defect in the resistor element.

Contact SPINNER After Sales Service to clarify how to proceed: [after-sales-service@spinner-group.com](mailto:after-sales-service@spinner-group.com)

### Performing the functional test annually maintenance:

Use the ▼ ▲ keys to call up the screen for the functional test. The screen displays the cooling time required to cool the resistor element from 80°C to 55°C at the set RF power. In addition, the current temperature of the resistor element is displayed. See video „Functional Test“ for detailed instructions at <https://www.spinner-group.com/en/products/smart-load-service>

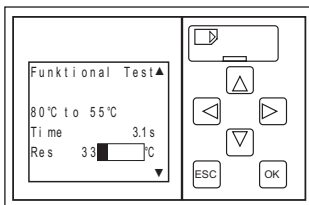

Funktional test screen for SmarLoads wit one rsistor.

or

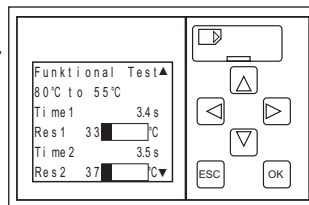

Funktional test screen for SmarLoads wit two rsistors.

### Manually activation of pump and fan:

Use the ▼ ▲ keys to call up the screen for pump and fan activation. Press the ESC key and the ▲ key simultaneously to switch on the pump and fan. After ten minutes, the pump and fan switch off again automatically. A counter shows the remaining running time. Pump and fan can be switched off again by pressing the ESC key and the ▼ key simultaneously.

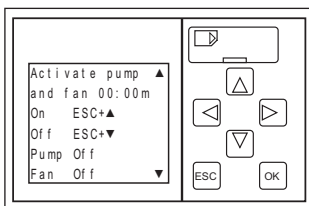

Indicates whether the pump and fan have been activated manually.