

Rotary Joint || BN 637484

Contactless Data and Power Transmission Channels

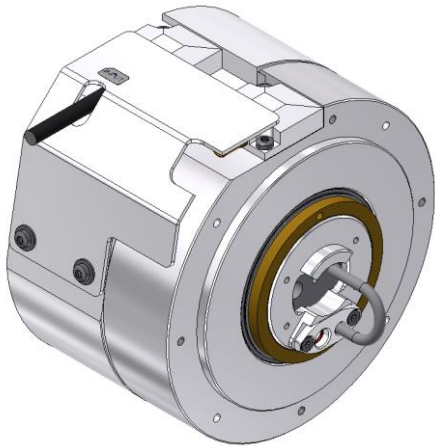

This combination of contactless data and power channels offers improved lifetime without the need for maintenance. The contactless design allows very high rotational speeds in comparison to slip ring designs.

The data channels are realized by rotating capacitive couplers and the power channel is based on an inductive technology.

- POWERLINK
- PROFINET
- EtherCAT
- SERCOS III
- EtherNet/IP
- VARAN
- IEEE-1588 v2 (PTP)

637484 – Standard outline

Available configurations

Type	Description	Standard product ordering number
1	1000BASE-T Ethernet	637484C0001
4	1 Channel ethernet for real-time applications 100BASE-TX, full duplex	637484C0004
5	1 Channel ethernet for real-time applications 100BASE-TX, half duplex	637484C0005
7	2 Channel ethernet (multiplexed) for real-time applications 100BASE-TX, full duplex	637484C0007
8	2 Channel ethernet (multiplexed) for real-time applications 100BASE-TX, half duplex	637484C0008

Transmission type 1:

1000BASE-T Ethernet-Channel	One contactless coupler for one channel
Supported ethernet standards	10BASE-T (IEEE802.3 Clause 14) 100BASE-TX (IEEE802.3 Clause 25) 1000BASE-T (IEEE802.3 Clause 40) Auto negotiation provided to select ethernet-standard and full/ half duplex mode automatically
OSI layer operation	Layer 1 - 2
Supported protocols	Not for real-time ethernet applications
Ethernet frame loss ratio according to RFC2544	$\leq 1 \times 10^{-9}$ Measured for 800s with 64 byte frames at 99% channel utilization, corresponds to BER $\leq 1 \times 10^{-12}$
Data interface connection	Cat.6A S/FTP 4x2xAWG26/7 (PiMF) at body and hollow shaft side (or special cable type according to specific circuit diagram)

SPINNER GmbH
This document is proprietary to us.
All rights reserved. Any use, transfer, or reproduction of this document
or the know-how contained therein requires our express consent.

Template TD-00015M

Rotary Joint || BN 637484

Transmission type 4 + type 5:

100BASE-TX Ethernet Channel	One signal channel provided	
	Type 4	Type 5
Supported ethernet standards	100BASE-TX (IEEE802.3 Clause 25), autonegotiation (full duplex only)	100BASE-TX (IEEE802.3 Clause 25), autonegotiation (half duplex only)
Supported protocols	Real-time ethernet protocols	
OSI layer operation	Layer 1 (physical)	
Ethernet frame loss ratio according to RFC2544	$\leq 1 \times 10^{-9}$ Measured for 8000s with 64 byte frames at 99% channel utilization, corresponds to BER $\leq 1 \times 10^{-12}$	
Data interface connection	Cat.6A S/FTP 4x2xAWG26/7 (PiMF) at body and hollow shaft side (or special cable type according to specific circuit diagram)	

Transmission type 7 + type 8:

100BASE-TX Ethernet Channel	Two signal channels over one contactless transmission channel, signals are multiplexed, no redundancy	
	Type 7	Type 8
Supported ethernet standards	100BASE-TX (IEEE802.3 Clause 25), autonegotiation (full duplex only)	100BASE-TX (IEEE802.3 Clause 25), autonegotiation (half duplex only)
Supported protocols	Real-time ethernet protocols	
OSI layer operation	Layer 1 (physical)	
Multiplexer	Time domain multiplexing	
Ethernet frame loss ratio according to RFC2544	$\leq 1 \times 10^{-9}$ Measured for 8000s with 64 byte frames at 99% channel utilization, corresponds to BER $\leq 1 \times 10^{-12}$	
Data interface connection	Cat.6A S/FTP 4x2xAWG26/7 (PiMF) at body and hollow shaft side (or special cable type according to specific circuit diagram)	

SPINNER GmbH | This document is proprietary to us. All rights reserved. Any use, transfer, or reproduction of this document or the know-how contained therein requires our express consent.

Template TD-00015M

Rotary Joint || BN 637484

Operating condition for data transmission

External Power Supply	Power Supply has to be a ES1 type acc. to DIN EN 62368-1 The current must be externally limited to 4 A
Input Voltage Range	21.6 V to 28.8 V DC; 0 V is connected to Case Ground internally
Current Consumption, typ. / max.	0.33 A / 0.5 A @ 24 V Supply Voltage
Inrush Current	3 A (duration 2 ms)
Power Consumption, typ. / max.	8 W/ 12 W
Supply Voltage Connection	2 x 0.25 mm ² LiYCY cable, shielded, outer diameter ~3.9 mm, at Body and Hollow shaft side (or special cable type according to specific circuit diagram)

Operating condition for DC power transmission

External power supply	Power Supply has to be a ES1 type acc. to DIN EN 62368-1 The current must be externally limited to 5 A	
Input voltage range	21.6 V to 28.8 V DC	
Output voltage	24 V DC ±3% potential free against case ground and data channels	
Output current to external load @ V _{in} > 21,6V	2.5 A	Over full temperature range
Output current to external load @ V _{in} < 21,6V	1.5 A	
Output voltage ripple, max.	80 mV	
Efficiency at external load, typ.	85% @ full load	
Supply voltage connection	2 x 0.75 mm ² LiYCY cable, shielded, outer diameter ~5.6 mm, at body and hollow shaft side (or special cable type according to specific circuit diagram)	

Standards and directives

Applicable EU Directive	EMC Directive 2014/30/EU	
Applied standards	DIN EN 55032 (Class B)	Radio disturbance characteristics
	DIN EN 55024	Immunity characteristics

SPINNER GmbH
 This document is proprietary to us.
 All rights reserved. Any use, transfer, or reproduction of this document
 or the know-how contained therein requires our express consent.

Template TD-00015M

Rotary Joint || BN 637484

Mechanical data

	Standard speed grade	High speed grade (optional)
Rotating speed, max. / nominal	300 rpm	4000 rpm
Life, min.	200 x 10 ⁶ revolutions	
MTBF	300 000 h	
Torque (room / min. temperature), max.	0.2 Nm / 0.5 Nm @ start-up 0.2 Nm / 0.5 Nm @ rotation	
Interface loads, max.	no loads allowed	
Case material	aluminum alloy	
Case surface finish	chromate conversion coat painted RAL9005 jet black	
IP protection level	IP60	
Weight, approx.	2.5 kg	
Marking	adhesive label	
Standard cable length	1400 mm ± 5 % (or special cable length according to specific data sheet)	

Environmental conditions

Operation	
Ambient temperature range	-30°C to +71°C
Relative humidity, max.	95% (non-condensing)
Shock	30 g / 11 ms half sine, 3 shocks in each direction of 3 orthogonal axes
Vibration	20-500 Hz, PSD of 0.02 g ² /Hz falling to 0.001 g ² /Hz at 500 Hz in each of 3 orthogonal axes Duration: 15 min/axis
Storage	
Ambient temperature range	-40°C to +85°C
Relative humidity, max.	95% (non-condensing)

Applicable documents

Specific Circuit Diagram	637484CXXXX-CD (XXXX according to ordering number)
Specific Data Sheet	637484CXXXX-BE (XXXX according to ordering number)

SPINNER GmbH | This document is proprietary to us. All rights reserved. Any use, transfer, or reproduction of this document or the know-how contained therein requires our express consent.

Template TD-00015M

Rotary Joint || BN 637484

Outline (all dimensions in millimeter)

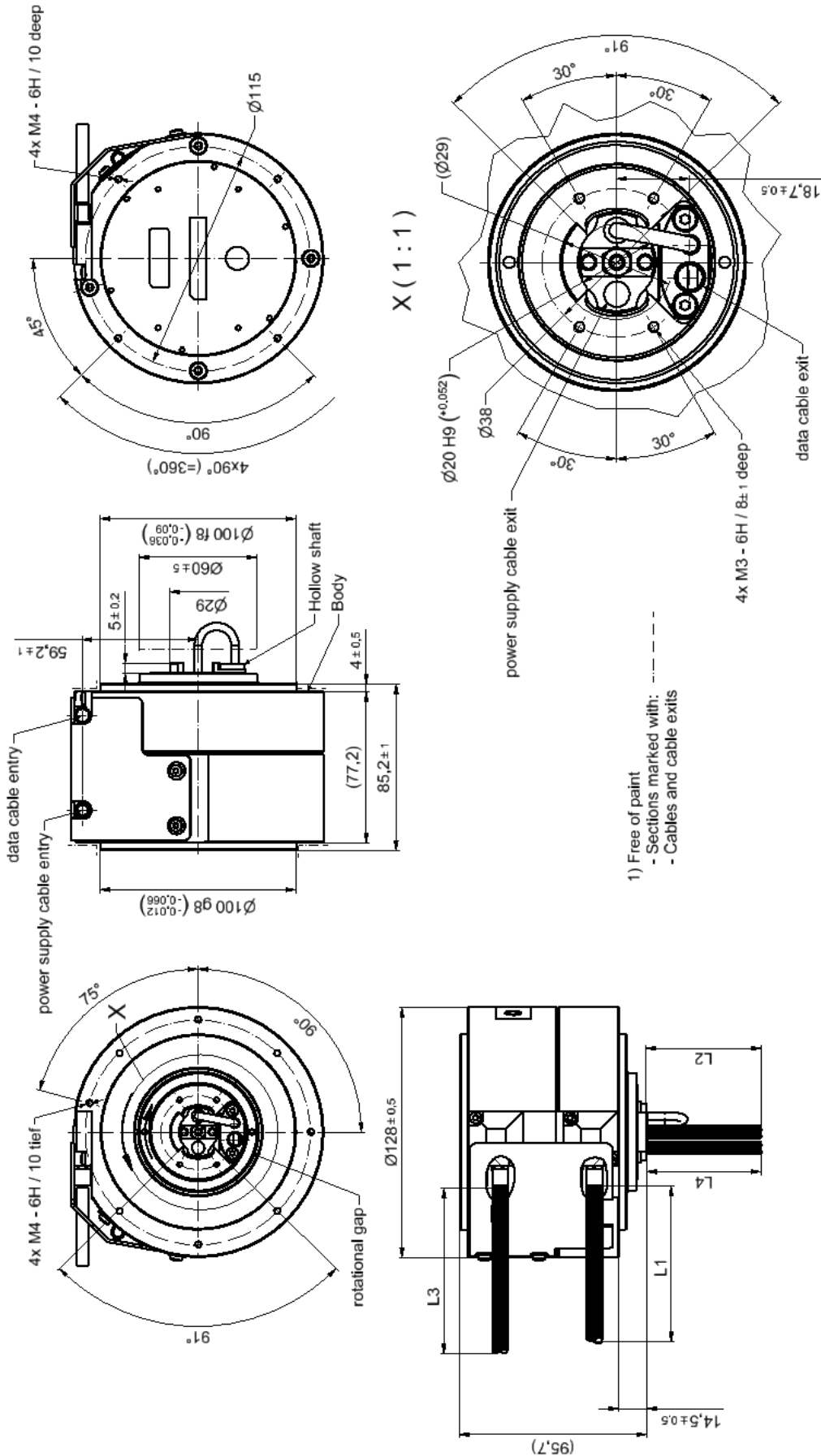

SPINNER GmbH
This document is proprietary to us.
All rights reserved. Any use, transfer, or reproduction of this document
or the know-how contained therein requires our express consent.

Template TD-00015M