



SPINNER I Product Manual

Original instructions

Dual SmartLoad 25 kW

BN 546434C0400



products.spinner-group.com

HIGH FREQUENCY PERFORMANCE WORLDWIDE

www.spinner-group.com

Content

1	Safety	3
1.1	About this product documentation.....	3
1.2	Intended use.....	3
1.3	Improper use	3
1.4	Qualifications of personnel.....	3
1.5	Safety signs and symbols	4
1.6	Signal words for hazard seriousness	4
1.7	Grouped safety messages for SPINNER broadcast products	5
2	Product identification	7
3	Function.....	7
3.1	General.....	7
3.2	Coolant	7
3.3	Heat exchanger	7
3.4	Coolant circuit of the liquid cooling system	8
3.5	Interlock loop	8
3.6	Operating and display elements.....	10
3.7	Maintenance cycle.....	10
4	Storage.....	10
5	Transportation	11
6	Installation	12
6.1	Mechanical installation	12
6.2	Coolant level check and overflow hose installation.....	14
6.3	Electrical installation.....	14
7	Commissioning and normal operation.....	16
8	Maintenance	17
8.1	PLC clock time setting.....	18
8.2	Deaeration of the cooling circuit	18
8.3	Checking glycol concentration	20
8.4	Correcting the coolant level.....	21
8.5	Coolant exchange	22
9	Warranty.....	23
10	Repairs	24
11	Demounting	24
12	Disposal.....	25
13	Spare Parts	26
14	Contacts	26

1 Safety

1.1 About this product documentation

The Spinner group makes every effort to keep the safety standard of our products up to date to be able to offer our customers the highest possible degree of safety. Our products are designed and tested in accordance with the relevant safety standards. There is, however, still a danger of personal injury or damage to equipment if this chapter and the safety instructions in this documentation are not complied with. This documentation aims at persons commissioned with the transport, installation, commissioning, operation, cleaning, maintenance, repairs, demounting and disposal of SPINNER SmartLoads. Read this documentation completely and particularly the chapter "Safety", before working with the product. Keep this product documentation available at the site and pass it on to the subsequent users. For all questions regarding the safety you can contact SPINNER at any time.

1.2 Intended use

The intended use of the product is to terminate RF high power coaxial transmission lines. The SmartLoad BN 546434C0400 is designed to absorb RF power of max. 25 kW in broadcast or industrial indoor applications in operating rooms with restricted access. Access for authorized persons shall be regulated by the operator.

Details and other limits are given in the attached data sheet 10086227.

The intended use of the product is assumed, if it is used in accordance with the requirements of the applicable product documentation and within its performance limits (see appendices data sheet, circuit diagram, material data sheet of the SPINNER coolant and the following safety instructions). Applicable local or national safety regulations and rules for the prevention of accidents must be observed in all work performed in conjunction with the product.

1.3 Improper use

The improper use of the product includes the use of the product:

- in operating rooms with unrestricted access
- in outdoor applications
- in explosion-prone atmosphere
- for transporting people or loads
- without correctly connected interlock system
- with covered inlet or exhaust air openings
- with modifications not authorized by SPINNER
- in damaged condition
- for private purposes
- in conditions and environments beyond the limits given in this product documentation

Any other use than described in the chapter intended use and in this product documentation is improper use and therefore inadmissible.

1.4 Qualifications of personnel













Installation, commissioning, operation, maintenance, repairs and demounting of the product require electrical and mechanical specialized knowledge. In order to ensure the safe use, these activities may therefore only be carried out by qualified technical personnel or an instructed person under the direction and supervision of qualified personnel. Qualified personnel are those who, due to professional training, knowledge and experience as well as their understanding of the relevant regulations, are able to assess the work assigned, to recognize possible hazards and to institute appropriate safety measures.

Qualified personnel must have appropriate safety equipment and must be trained in first aid.

The use of the product requires special training and a high level of concentration. It must be ensured that persons who use the product are physically, mentally and emotionally able to comply with the requirements, otherwise injuries or material damage may occur. The employer or operator must choose suitable personnel for use of the product.

1.5 Safety signs and symbols

Safety signs are used on warning labels, stickers, in the product documentation and on the packaging of the product.

					
Warning! General hazard	Warning! Danger of electric shock	Warning! Hot surface	PE terminal	Earth	Warning! High weight
					
Warning! Non-ionised electromagnetic radiation	No access for persons with pacemakers	Use safety shoes	Use safety helmet	Use safety gloves	Observe product documentation

1.6 Signal words for hazard seriousness

Signal words are used on warning labels, stickers, in the product documentation, on specific danger spots and on the packaging of the product. They indicate the hazard seriousness in safety messages.

- DANGER** Indicates a hazardous situation conveying great risk which, if not avoided, will result in death or serious injury.
- WARNING** Indicates a hazardous situation conveying moderate risk which, if not avoided, could result in death or serious injury.
- CAUTION** Indicates a hazardous situation conveying minor risk which, if not avoided, may result in minor or moderate injury.
- NOTICE** Indicates the possibility of faulty operation that can damage the product.

It is essential to make sure that the signal words described here are always used only in connection with the related product documentation and the related product. The use of signal words in connection with unrelated products or documentation can result in misinterpretation and thus contribute to personal injury or material damage.

1.7 Grouped safety messages for SPINNER broadcast products

Entire or multiple phases of product lifecycle

- Unless otherwise specified, these products are not protected against penetration of liquids, gases, steam, etc. Failure to comply could result in electric shock or product damage, which could also lead to serious injury.
- Blocking of constructive openings on the product (ventilation slots, fine leaks etc.) must be prevented, because these are necessary for product operation. Failure to comply could lead to overheating and could result in burns, fire and electric shock.
- Any object that is not designed to be placed in the openings of the housing must not be used for this purpose. Doing so can cause short circuits inside the product and could result in electric shock, fire or injury.
- Depending on the function, certain products such as RF radio equipment can produce an elevated level of electromagnetic radiation. Considering that unborn babies require increased protection, pregnant women must be protected by appropriate measures. Persons with pacemakers may also be exposed to risks from electromagnetic radiation. The employer/operator must evaluate workplaces where there is a special risk of exposure to radiation and, if necessary, take measures to avert the potential danger.
- As with all industrially manufactured goods, the use of substances that induce an allergic reaction (allergens) such as nickel cannot be generally excluded. If you develop an allergic reaction (such as a skin rash, frequent sneezing, red eyes or respiratory difficulties) when using a SPINNER product, consult a physician immediately to determine the cause and to prevent health problems or stress.
- Should a fire occur, the product may release hazardous substances (gases, fluids, etc.) that can cause health problems. Therefore, suitable measures must be taken, e.g. protective masks and protective clothing must be worn.

Transport

- The product may be very heavy. In some cases, the user may require suitable lifting gear and means of transportation to avoid back or other physical injuries.
- Transport the product only in the original packaging. Do not unpack until immediately prior to installation. Failure to comply could result in death or serious injury.

Installation

- Do not place the product on heat-generating devices such as radiators or fan heaters. The ambient temperature must not exceed the maximum temperature specified in the product documentation or in the data sheet. Product overheating could result in burns, fire and electric shock.
- Do not place the product on surfaces, vehicles, cabinets or tables that for reasons of weight or stability are unsuitable for this purpose. Always follow the installation instructions of the manufacturer when installing the product and fastening it to objects or structures (e.g. walls and shelves). An installation that is not carried out as described in the product documentation could result in death or serious injury.
- Mains driven products must be operated only from a TN power distribution system. The operator is responsible for using an appropriate and sufficiently dimensioned AC power line. The AC power line must be externally fused according to the product documentation. Failure to comply could result in fire or electric shock.
- Operation of products with protection class I according to EN 61140 is permitted only with a mains cable with protective earth connection. The protective conductor continuity must be inspected by an electrically skilled person. Failure to comply could result in electric shock.

- All externally connected circuits for controlling, alerting and signalling have to be fed from ES1 type sources acc. to IEC 62368-1 only. The current in these circuits has to be externally limited by means of fuses to values indicated in the product documentation. Failure to comply could result in fire and electric shock.
- Dangerous voltage must not reach the product over the outer conductor/waveguide. Failure to comply could result in electric shock.
- If the product is equipped with a ground terminal connection (equipotential connection), the ground terminal must be connected sufficiently dimensioned to earth. Failure to comply could result in electric shock.

Commissioning / Operation

- Products in operation may be hot. Touching them could result in burns.
- Before applying RF-power to the product, ensure proper connection and matching (load, line, etc.) of all RF-connectors. Ensure sufficient mechanical rigidity of the RF-connections. Failure to comply could result in serious injuries by non-ionised electromagnetic radiation.
- Operation of the product with a damaged cable is not permitted. All cables must be checked on a regular basis to ensure that they are in proper operating condition. By taking appropriate safety measures and carefully laying the power cable, ensure that the cable cannot be damaged and that no one can be hurt or suffer an electric shock by e.g. tripping over the cable.
- Front panels, lids and covers must not be removed during operation. Otherwise, live components can be accessible. This could result in electric shock, fire and serious injury.
- If the product is subjected to pressure, the locally and nationally applicable guidelines for pressure vessels must be applied. Failure to comply could result in death or serious injury.

Cleaning

- Prior to cleaning, turn off all feeding transmitters and disconnect them from the power supply. Use a soft, lint-free, dry cloth for cleaning. Do not use chemical cleaners. Perform cleaning only after cooling-down. Failure to comply could result in electric shock and burns.

Repair

- Troubleshooting and repairs should only be carried out by qualified technical personnel or an instructed person under the direction and supervision of qualified personnel (see chapter 1.4 "Qualifications of personnel"). Observe the section safety messages and in particular chapter 1 "Safety" of this product manual. Failure to comply could result in death or serious injury.
- Do not modify the product and use only spare parts tested and approved by SPINNER. Failure to comply could result in death or serious injury.

Disposal

- The operator is responsible for disposing of the product according to national waste disposal regulations. Improper disassembly or disposal may be hazardous.
- If hazardous substances or operation materials are used for operation of the product, which must be periodically disposed of (e.g. coolant), these materials must be treated in accordance with the safety instructions of the hazardous substance or operating material manufacturer and the national waste disposal regulations. Also observe the relevant safety instructions in this product documentation. Failure to comply could result in serious injury and environmental damage.

2 Product identification

The SPINNER SmartLoads BN 546434C0400 has a type plate containing the following information for product identification:

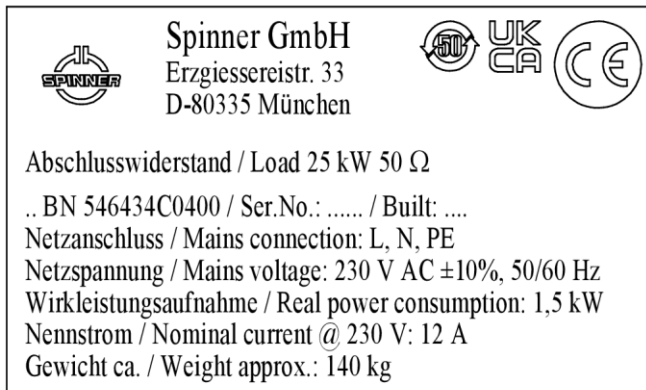

3 Function

3.1 General

The SmartLoad has two resistor elements, each consisting of a cylindrical ceramic substrate coated with special resistive material, to absorb the RF power and convert it into heat. An unpressurized liquid cooling system with coolant pump and closed cooling circuit is used for transferring the heat from both resistor elements, via a heat exchanger with forced air cooling, to the surrounding area.

3.2 Coolant

The coolant ANTIFROGEN N is a well-balanced yellow coloured mixture of distilled water, ethylene glycol and a rust preventative. The composition ensures excellent protection against corrosion and freezing. The coolant supplied is a mixture of distilled water, 39% by volume ethylene glycol and a corrosion inhibitor.



Observe the attached material data sheet of the coolant when filling up, emptying or deaerating the cooling system or disposing of the coolant. For an updated copy of the material data sheet refer to the link or QR code below:

<https://products.spinner-group.com/AntifrogenN>



3.3 Heat exchanger

A radiator fan is used for re-cooling of the heat sink.

NOTICE Ensure unobstructed air circulation to avoid overheating.

3.4 Coolant circuit of the liquid cooling system

A pressureless closed cooling circuit with radiator fan is used for heat release. The coolant is pumped through the resistor elements W1, W2 and the heat exchanger K by means of the coolant pump P. The expanse vessel AB is added due to the thermal expansion of the coolant. The outer surface temperatures of the resistor elements and the coolant temperature are monitored by means of the temperature controllers B1.1, B1.2 and B2. Leakage from the resistor elements is monitored by the float switches B3.1 and B3.2.

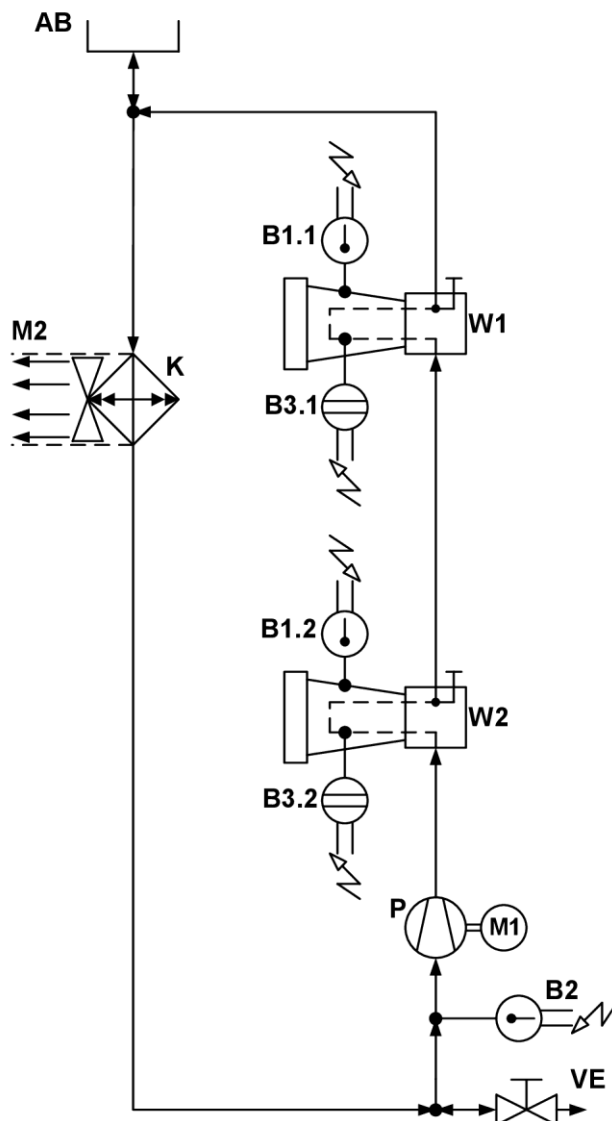

Legend:

- AB: Expanse vessel
- B1.1: Temperature controller resistor input 1
- B1.2: Temperature controller resistor input 2
- B2: Temperature controller coolant
- B3.1: Float switch input1
- B3.2: Float switch input2
- K: Heat exchanger
- M1: Motor coolant pump
- M2: Radiator fan (Heat exchanger)
- P: Pump
- VE: Filling/drain valve
- W1: Resistor element input 1
- W2: Resistor element input 2

3.5 Interlock loop

The internal interlock loops for protection of the SmartLoad consist of a programmable logic controller (PLC), temperature controllers, float switches and signal contacts. The logic of the PLC combines all seven sensory inputs like switches connected in series to control the interlock loop, which is closed during normal operation of the SmartLoad. The interlock switching contacts B1.1 and B1.2 switch off the two transmitters connected to the contact points J2.1 and J2.2 independently of each other. Any other switch - when open - shuts down both transmitters at once, which are connected to the interlock loop at connection point J2.1 and J2.2.

- The temperature controller B1.1 respectively B1.2 opens at resistor temperatures above 260 °C. After opening the interlock at 260 °C the load element needs to cool down to 60 °C before the interlock is closed again. The overtemperature threshold will be reduced gradually to 190 °C and 120 °C to keep the load element temperatures in a safe range. Between the interlock open temperature of 120 °C and the interlock close temperature of 60 °C unlimited operation is possible. After 6 hours of trouble-free operation or a power cycle the interlock open threshold will be reset to 260 °C.
- The temperature controller B2 opens at coolant temperatures above 90 °C and closes below 80 °C.
- The float switch B3.1 respectively B3.2 opens when a coolant leak is detected.
- The protection function of the frequency inverter VFD1 for the coolant pump motor M1 opens at coolant pump motor overload.
- The protection function of the frequency inverter VFD2 for the ventilator motor M2 opens at ventilator motor overload.
- The main switch interlock is open in power off position of the main switch.



WARNING

Electric shock hazard

Electric shock can cause severe burns and fatal injuries.

Do not use the interlock loop for personal protection

Schematic diagram of the switching status during normal operation:

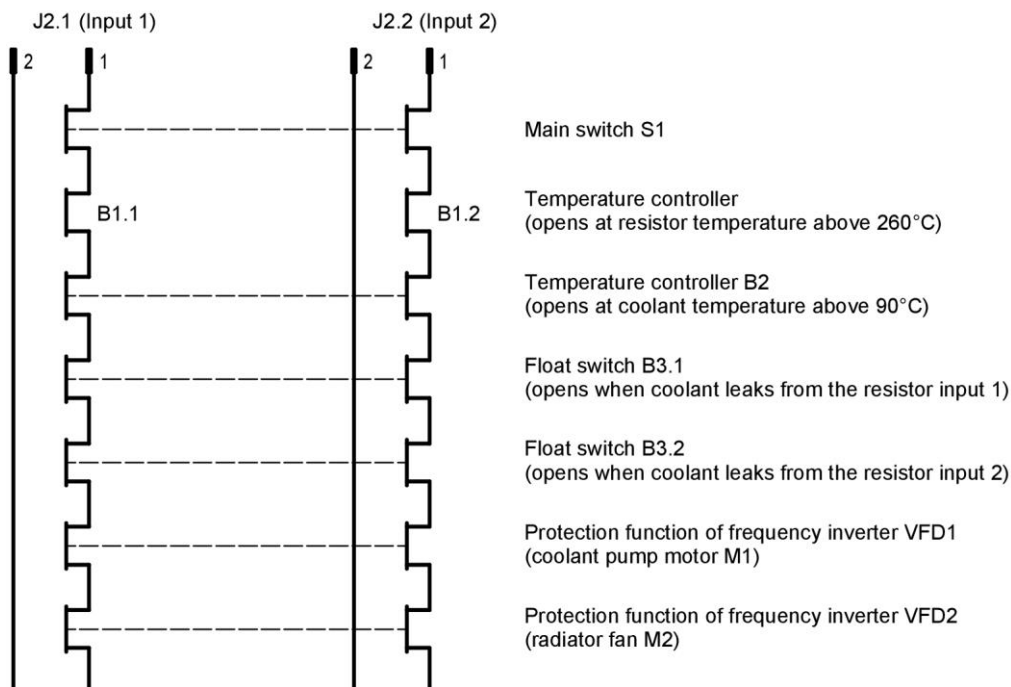

The internal interlock loops comply with the requirements for Electrical energy Source class 1 (ES1 type according to IEC 62368-1, safe separation, proof voltage resistance 4 kV ACpk to primary circuit).

The maximum permissible voltage for the interlock loops and to the grounded housing is 42.4 V ACpk respectively 60 V DC. The power supply must be fully compliant with the ES1 type requirements. The circuit has to be limited externally to 1 A.

3.6 Operating and display elements

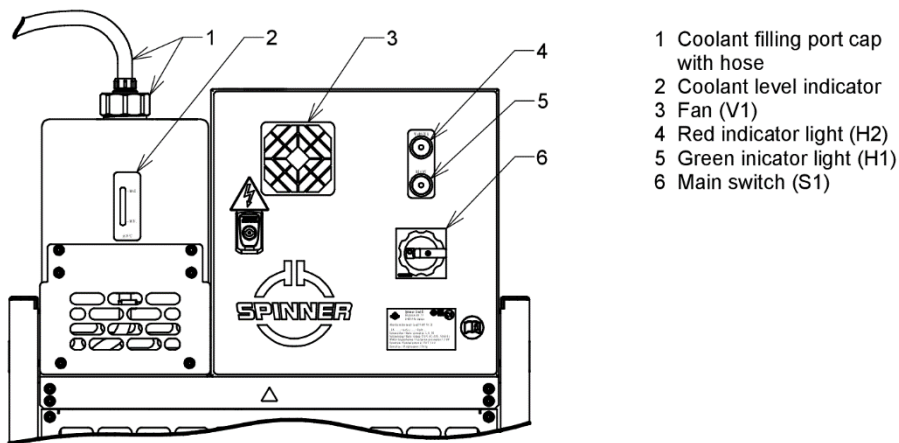

- 1 Coolant filling port cap with hose
- 2 Coolant level indicator
- 3 Fan (V1)
- 4 Red indicator light (H2)
- 5 Green indicator light (H1)
- 6 Main switch (S1)

Green indicator light “READY“:

Some 10 seconds after power-on, the green light indicates readiness for operation:

- Mains voltage is connected
- Main switch is turned on
- No fault occurred

Red indicator light “WARNING“:

The red light indicates that an interlock loop of the SmartLoad is interrupted. All transmitters connected properly to this interlock loop are turned off.

The red indicator lamp lights, if the mains voltage is connected, the main switch is turned on and at least one of the following five conditions is true:

- Temperature of a resistor element too high
- Coolant temperature too high
- Float switch of a resistor element triggered
- Motor protection VFD1 triggered
- Motor protection VFD2 triggered

Front panel fan

The fan mounted on the front panel of the control cabinet is required for cooling of the frequency inverters FU1 and FU2. The fan runs if the coolant pump is operating at full speed.

3.7 Maintenance cycle

To ensure proper longterm operation of the coolant pump, the PLC activates autonomous maintenance cycles daily for the duration of a few minutes, refer to “PLC clock time setting” in the attached PLC manual 10058594.

4 Storage

Keep dry and avoid exposure to sudden temperature changes to prevent condensation. Environmental conditions for storage are specified in the attached data sheet 10086227. Do not unpack until immediately prior to installation.

NOTICE

Do not remove any connector protection cap until immediately prior to installation to avoid formation of dust and scratches on sensitive RF contact surfaces. Environmental conditions for storage refer to attached data sheet TD-00060

5 Transportation



CAUTION

Crushing Hazard

The SmartLoad is heavy. Crushing or falling may cause injuries.

Use suitable lifting gear approved to carry at least 160 kg.

Do not stand below the SmartLoad.

To ensure stability, keep the product in the supplied transport packaging until immediately prior to installation.

Do not lift the SmartLoad at the RF connectors.

Do not stress the expense vessel and the control cabinet.

Safety shoes and hardhat are required.



NOTICE

Environmental conditions for transportation refer to attached data sheet TD-00060



do not stress

straps

do not stress

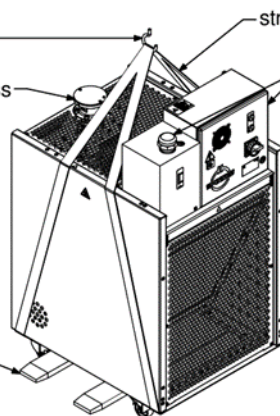

do not stress

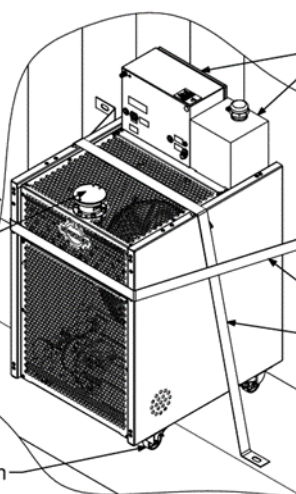

do not stress

fixing straps

lock all swivel castors with double stop if present

6 Installation



Before you start, ensure to read and understand the section safety messages and in particular chapter 1 "Safety" of this product manual. Only electrically skilled persons should install SPINNER SmartLoads in accordance with the national safety and accident prevention regulations. Failure to observe could result in death or serious injury.

6.1 Mechanical installation



WARNING

Crushing Hazard

Falling objects may cause death and serious injury.

The SmartLoad is heavy. Use suitable lifting gear only. The lifting gear must be approved to carry at least 160 kg.

Do not lift the SmartLoad at the RF connectors.

Do not stress the expand vessel and the control cabinet.

Use suitable fasteners if mounted in an elevated position.

Safety shoes are required. If it is necessary to stand below the SmartLoad during installation, safety shoes and hardhat are required.



WARNING

Electric shock hazard

Electric shock can cause severe burns and fatal injuries.

Do not install and operate the SmartLoad in environmental conditions beyond the specifications given in the attached data sheet 10086227. The SmartLoad is designed for indoor application on operating sites with limited access only.



Floor installation:

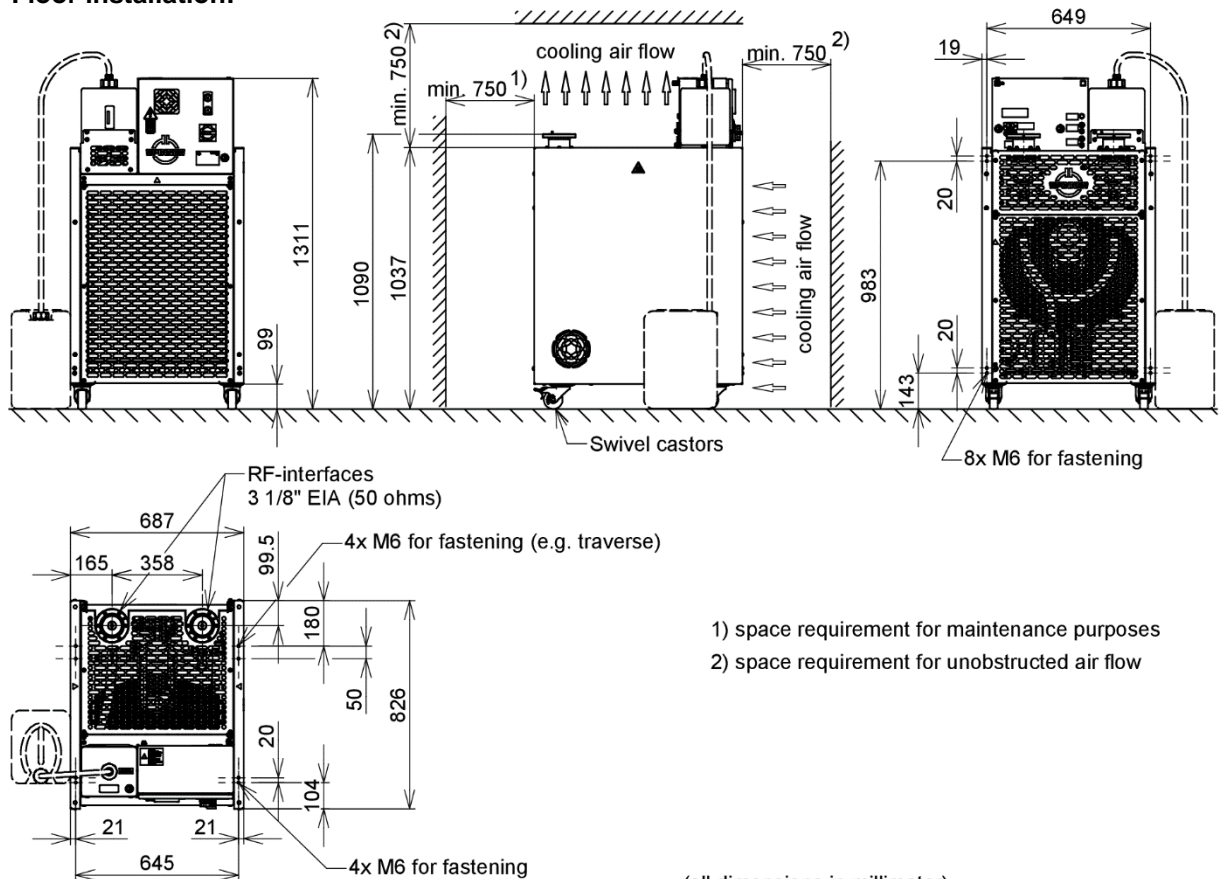

The SmartLoad must be installed on a flat and solid ground with bearing capacity higher than 160 kg to ensure stability. The front panel, main switch and filling port need to be easily accessible. Do not install the SmartLoad on escape routes, corridors or close to temperature sensitive equipment. Required floor space for best possible cooling capacity is specified in the installation drawing above. For fixing lock the swivel castors after positioning or use the lower M6 mounting threads. The M6 threads near to the RF connector can be used for mounting a traverse to support the RF cable.

NOTICE Ensure unobstructed air circulation to avoid overheating.
Do not reduce the ground clearance if installed without wheels.

Ceiling installation:

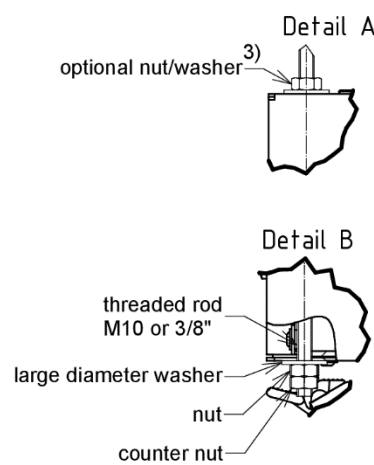
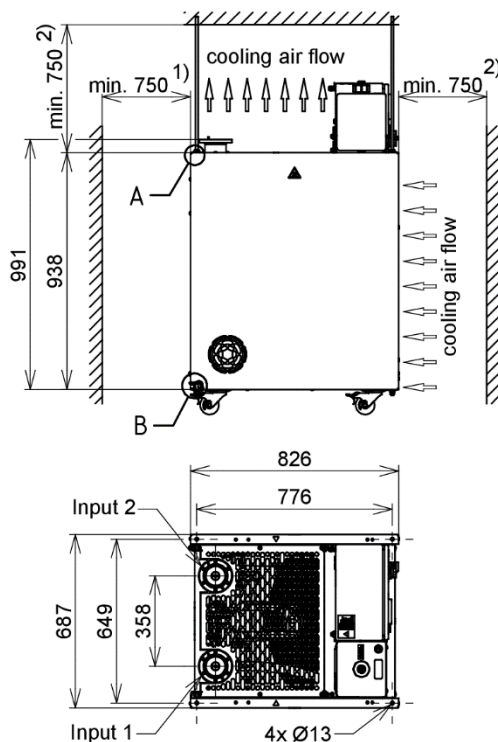

- 1) space requirement for maintenance purposes
- 2) space requirement for unobstructed air flow
- 3) To hold the threaded rod in position before ceiling mounting, a nut can optionally be attached to the top of the housing

Pictures show fixing material exemplary
(all dimensions in millimeter)

The SmartLoad must be installed on a solid ceiling with bearing capacity higher than 500 kg to ensure stability. The front panel, main switch and filling port need to be easily accessible. Do not install the SmartLoad close to temperature sensitive equipment. Ensure sufficient pass line heights and the required cooling air flow space, refer to floor installation.

NOTICE Ensure unobstructed air circulation to avoid overheating.

Threaded rod through the housing: M10 or 3/8"
Tensile strength min. 400 N/mm²
Yield point min. 240 N/mm²

Recommended tightening torque for counter nut: 30 Nm

6.2 Coolant level check and overflow hose installation

SPINNER supplies the SmartLoad with correct coolant level and deaerated cooling circuit. The SmartLoad is equipped with a level indicator. The marking indicates the minimum and the maximum permissible level of the coolant.

NOTICE The coolant level may exceed the marked maximum at temperatures above 25 °C.
 Check the coolant level prior to commissioning.
 Prevent dry running of the coolant pump.
 Follow the instructions given in chapter 8.4 if correction of the coolant level is required.

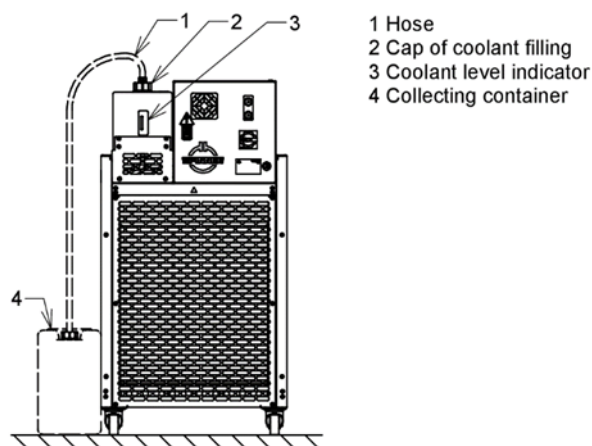

Connect the supplied hose (1) to the cap (2). Place a suitable collecting container (4) with a capacity of at least 10 l next to the SmartLoad and insert the hose (1) into the collecting container (4). In the event of a malfunction with a sudden rise in pressure in the cooling circuit, escaping coolant is drained via the hose into the collecting container.

The expansion tank has a membrane for continuous adaptation to the ambient pressure.

6.3 Electrical installation



WARNING

Electric shock hazard

Electric shock can cause severe burns and fatal injuries.

Before you start ensure to disconnect your entire system from the power supply. Utilize appropriate devices and methods to prevent accidental energizing.



WARNING

High leakage current

Connect a PE conductor of at least 10 mm² permanently to the separate PE terminal before connecting the mains connector.



WARNING

Radio Frequency Hazard

Radio Frequency Power can cause burns, eye injuries and electrical shock.

Before connecting the RF cable, ensure to disconnect your entire system from the power supply. Utilize appropriate devices and methods to prevent accidental energizing.

NOTICE To avoid overheating caused by RF overload ensure to connect all relevant transmitters to the interlock system of the SmartLoad prior to commissioning.

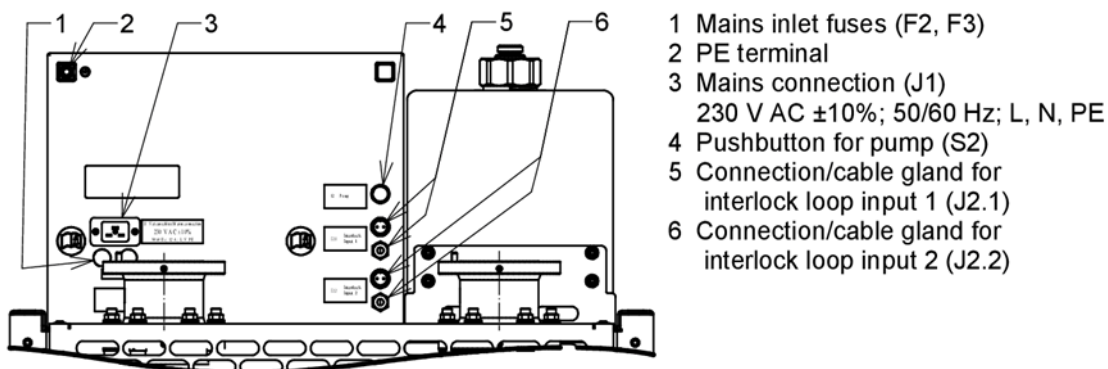

- Connect a PE conductor of at least 10 mm² with cable lug permanently to marked separate PE terminal, either at the top of the switch cabinet (M8 screw) or at the bottom on the rear of the frame (M8 screw), before connecting any other wire.

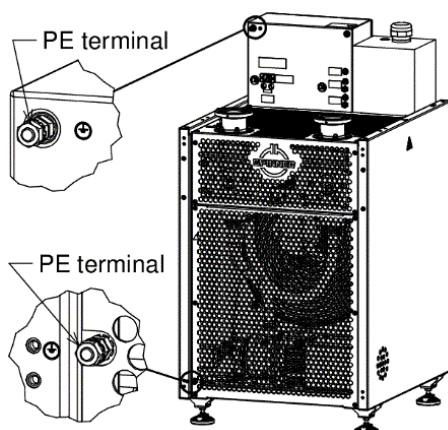

- Connect the interlock loop:
 Option 1:
 Mount the supplied interlock loop connector on a suitable cable and attach the connector to the two-pole screw locking IEC 60130-9 port on the rear side of the control box.
 Option 2:
 Alternatively use the cable gland on the rear side of the control box to run the interlock cable to the terminals inside the control box in accordance with the attached circuit diagram 10085157. Push a screwdriver into the rectangular opening of the clamp, insert the wire into

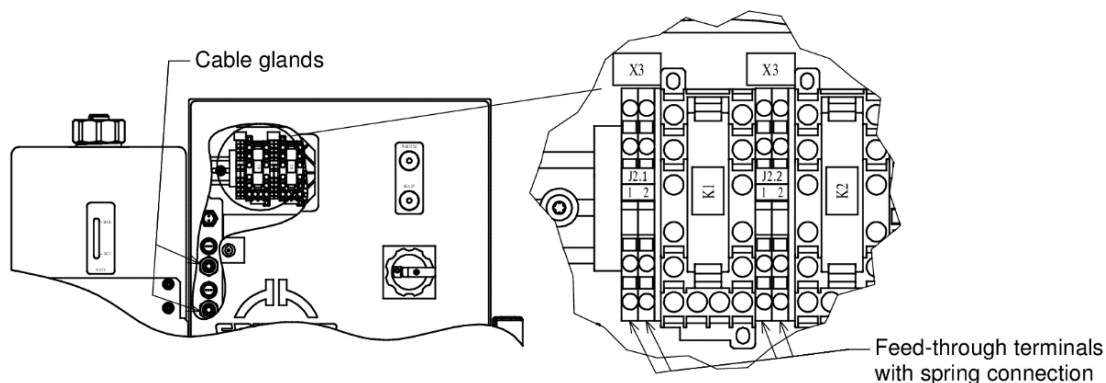

the round opening and then pull out the screwdriver.

Check proper function of the interlock system prior to commissioning. Do not use the interlock loop for personal protection.

The maximum permissible voltage for the interlock loop and to the grounded housing is 42.4 V ACpk respectively 60 V DC. The power supply must be fully compliant with the ES1 type requirements according to IEC 62368-1. The circuit has to be limited externally to 1 A.

- Mount a suitable mains connector to the supplied IEC 60320-1 C19 socket power cord according to the attached circuit diagram. Mains connector requirements:
230 V AC, 50 Hz to 60 Hz, 16 A, 3x2.5 mm²
Alternatively, a standard mains cable with a cross-section of 3x2.5 mm² and an IEC 60320-1 C19 socket can be used.
Use an easily accessible socket located close to the SmartLoad for mains connection. Connect the SmartLoad only to TN networks (L, N, PE):
230 V AC, 50 Hz to 60 Hz
- Connect RF using connectors according to IEC 339 only.
- Relieve all connections to the SmartLoad from any bending torque, e.g. caused by heavy cables or assemblies.
- Check sufficiently dimensioned PE-connection and PE-continuity prior to commissioning.
- Check functioning of the interlock loops by turning the main switch (S1) into the off position.

7 Commissioning and normal operation



Before you start, ensure to read and understand the section safety messages and in particular chapter 1 "Safety" of this product manual. Only electrically skilled persons may commission and operate SPINNER SmartLoads in accordance with the national safety and accident prevention regulations. Failure to observe could result in death or serious injury.

For latest maintenance procedures and updates, please check our website <https://www.spinner-group.com/en/products/smart-load-service> regularly at least every six months and register your product there.



Before applying RF power to the SmartLoad electrically skilled persons have to ensure:

- proper connection of all system connectors
- proper functioning of the interlock loops, all relevant transmitters must be connected to the interlock system of the SmartLoad.
- unobstructed air circulation; do not cover the ventilation openings.
- the SmartLoad is switched on; the green indicator lights.

After each actuation of the main switch the device runs a maintenance cycle. During this cycle the red indicator lights and the interlock loop is open. No RF power can be absorbed.

Open the switch cabinet and set, if applicable, the clock time and date as described in the attached PLC manual 10058594.

During operation, the pump and fan switch on at intervals. The length of the intervals depends on the RF power applied and the ambient temperature.

8 Maintenance



Before you start, ensure to read and understand the section safety messages and in particular chapter 1 "Safety" of this product manual. Only trained persons may clean SPINNER SmartLoads in accordance with the national safety and accident prevention regulations.
Failure to observe could result in death or serious injury.



WARNING

Electric shock hazard

Electric shock can cause severe burns and fatal injuries.

Before you start ensure to disconnect your entire system from the power supply. Utilize appropriate devices and methods to prevent accidental energizing. Do not use any liquids for cleaning.



WARNING

Entanglement Hazard

The ventilators may entangle hair, clothing or jewelry causing death or serious injury.

Wait until all rotating parts have stopped.
Wear a hair net and close-fitting clothing.



CAUTION

Hot surface

The resistor element heats up during normal operation and may cause burns. Do not remove any covers.
Do not touch the resistor element before cooled down

Detailed maintenance descriptions and videos are available at:

<https://www.spinner-group.com/en/products/smart-load-service>



Maintenance schedule:

Weekly:

- Verify correct coolant level and ensure that there are no leaks present.
- Ensure that there are no black particles and / or burned smell.
- Press pump button on back of electrical cabinet for a few seconds to activate pump for check. Check again for leakage.

Monthly:

- Verify the unobstructed air circulation of the heat exchanger. Remove dust or dirt from the heat exchanger with compressed air or a soft brush.

Quarterly:

- Verify installed software is the most current revision, refer to <https://www.spinner-group.com/en/products/smart-load-service>

Annually:

- Perform functional test on all reject SmartLoads. See video "Functional Test" for detailed instructions, refer to <https://www.spinner-group.com/en/products/smart-load-service>
- Check if the filter on fan of electrical cabinet is saturated with dust. If so, it can be vacuum cleaned or shook out and used again. In dusty environments, we recommend cleaning the filter regularly to avoid decreasing fan performance.
- Check glycol concentration, refer to chapter 8.3.

Every 4 years:

- Exchange coolant, refer to chapter 8.5.

8.1 PLC clock time setting



Before you start, ensure to read and understand the section safety messages and in particular chapter 1 "Safety" of this product manual. Only electrically skilled persons may open the control box of SPINNER SmartLoads and set the PLC clock time in accordance with the national safety and accident prevention regulations.

Details are given in the attached PLC manual 10058594.

8.2 Deaeration of the cooling circuit



Before you start, ensure to read and understand the section safety messages and in particular chapter 1 "Safety" of this product manual. Observe the material data sheet of the coolant. Only qualified personnel may deaerate SPINNER SmartLoads in accordance with the national safety and accident prevention regulations.

Failure to observe could result in death or serious injury.



WARNING

Electric shock hazard

Electric shock can cause severe burns and fatal injuries.

Before you start ensure to disconnect your entire system from the power supply. Utilize appropriate devices and methods to prevent accidental energizing.



WARNING

Radio Frequency Hazard

Radio Frequency Power can cause burns, eye injuries and electrical shock.

Before you start ensure to disconnect your entire system from the power supply. Utilize appropriate devices and methods to prevent accidental energizing.



CAUTION

Hot surface

The resistor elements heat up during normal operation and may cause burns.

Do not remove any covers shortly after use of the SmartLoad.

Do not touch the resistor elements before cooled down.



CAUTION

Poisoning Hazard

Skin or eye contact may cause irritation. Inhaling may irritate the respiratory organs.

Avoid skin or eye contact. Do not inhale gases, fumes and aerosols. Observe the attached safety data sheet M36457 of the coolant.



Wear safety gloves



Wear eye protection

1. Check coolant level and refill coolant if required (refer to chapter 8.4)

2. Deaeration of the cooling circuit:

- Wait until no more air bubbles appear in the expansion tank.
- Connect interlock and mains cables.
- Turn on the main switch.

NOTICE Pump must not run dry.

- Push the pump button for 2 min, then stop and wait until no more bubbles come up in the reservoir. Repeat this procedure a few times until no more bubbles show up.

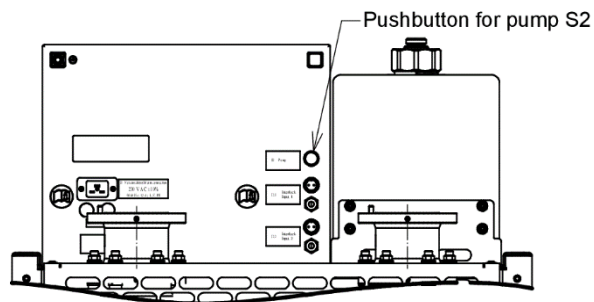

NOTICE Faultless functioning of the SmartLoad can only be guaranteed, if the cooling system is deaerated properly. The coolant has to be clear and free of any bubbles.

8.3 Checking glycol concentration



Before you start, ensure to read and understand the section safety messages and in particular chapter 1 "Safety" of this product manual. Observe the material data sheet of the coolant. Only qualified personnel may check the glycol concentration of SPINNER SmartLoads in accordance with the national safety and accident prevention regulations. Failure to observe could result in death or serious injury.



WARNING

Electric shock hazard

Electric shock can cause severe burns and fatal injuries.

Before you start ensure to disconnect your entire system from the power supply. Utilize appropriate devices and methods to prevent accidental energizing.



WARNING

Radio Frequency Hazard

Radio Frequency Power can cause burns, eye injuries and electrical shock.

Before you start ensure to disconnect your entire system from the power supply. Utilize appropriate devices and methods to prevent accidental energizing.



CAUTION

Poisoning Hazard

Skin or eye contact may cause irritation. Inhaling may irritate the respiratory organs.

Avoid skin or eye contact. Do not inhale gases, fumes and aerosols.

Observe the attached safety data sheet M36457 of the coolant.



Wear safety gloves



Wear eye protection

Check for sufficient glycol concentration and the pH-value of the coolant at least annually.

Unscrew the cap of the coolant filling port.

- Measure glycol concentration with usual antifreeze testing device for ethylene glycol. The optimum glycol concentration is 50 % (equals antifreeze up to -40 °C).

Below 40 % glycol concentration (equals antifreeze up to -27 °C) Coolant needs to be replenished. Drain off excess coolant at the reservoir.

Above 57 % glycol concentration (equals antifreeze up to -50 °C) thin down coolant with distilled water. Drain off excess coolant at the reservoir.

Screw on cap of filling port.

8.4 Correcting the coolant level



Before you start, ensure to read and understand the section safety messages and in particular chapter 1 "Safety" of this product manual. Observe the material data sheet of the coolant. Only qualified personnel may correct the coolant level of SPINNER SmartLoads in accordance with the national safety and accident prevention regulations. Failure to observe could result in death or serious injury.

WARNING



Electric shock hazard

Electric shock can cause severe burns and fatal injuries.

Before you start ensure to disconnect your entire system from the power supply.

Utilize appropriate devices and methods to prevent accidental energizing.

Do not to spill any coolant into the housing of the SmartLoad.

WARNING



Radio Frequency Hazard

Radio Frequency Power can cause burns, eye injuries and electrical shock.

Before you start ensure to disconnect your entire system from the power supply.

Utilize appropriate devices and methods to prevent accidental energizing.

CAUTION



Poisoning Hazard

Skin or eye contact may cause irritation. Inhaling may irritate the respiratory organs.

Avoid skin or eye contact. Do not inhale gases, fumes and aerosols.

Observe the attached safety data sheet M36457 of the coolant.



Wear safety gloves



Wear eye protection

Refilling of coolant is necessary at coolant level below the marked minimum. The coolant level may exceed the marked maximum at temperatures above 25 °C.

NOTICE

If refill is required, use only coolant according to the specifications given in the attached data sheet.

Required coolant: ANTIFROGEN N, SPINNER BN 39463A (20 l canister)

Do not refill coolant via the hose or the hose connection.

Deaeration of the cooling circuit is mandatory after refilling (refer to chapter 8.2).

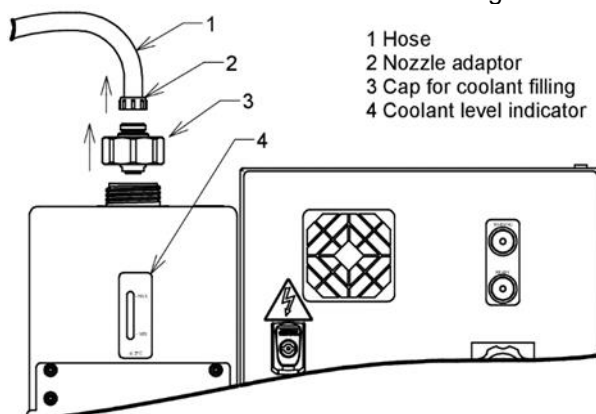

To refill, remove the cap (3), if necessary, unscrew the nozzle adaptor (2) with hose (1) beforehand.

8.5 Coolant exchange



Before you start, ensure to read and understand the section safety messages and in particular chapter 1 "Safety" of this product manual. Observe the material data sheet of the coolant. Only qualified personnel may correct the coolant level of SPINNER SmartLoads in accordance with the national safety and accident prevention regulations.

Failure to observe could result in death or serious injury.

WARNING

Electric shock hazard



Electric shock can cause severe burns and fatal injuries.

Before you start ensure to disconnect your entire system from the power supply.

Utilize appropriate devices and methods to prevent accidental energizing.

Do not to spill any coolant into the housing of the SmartLoad.

WARNING

Radio Frequency Hazard



Radio Frequency Power can cause burns, eye injuries and electrical shock.

Before you start ensure to disconnect your entire system from the power supply.

Utilize appropriate devices and methods to prevent accidental energizing.

CAUTION

Poisoning Hazard



Skin or eye contact may cause irritation. Inhaling may irritate the respiratory organs.

Avoid skin or eye contact. Do not inhale gases, fumes and aerosols.

Observe the attached safety data sheet M36457 of the coolant.



Wear safety gloves



Wear eye protection

1. Empty the cooling circuit:

- Turn off the main switch.
- Before draining the coolant, make sure the coolant has cooled down to room temperature.

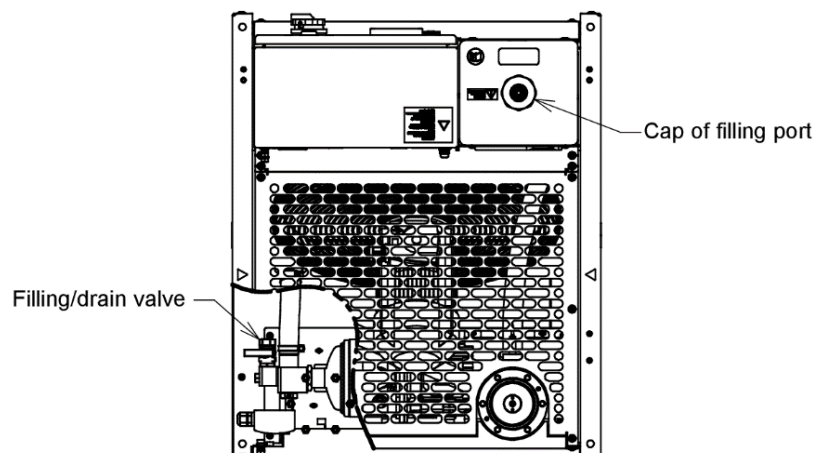

- Remove the nozzle adapter with hose from the filling cap and unscrew cap of filling port.
 - Remove rear cover.
 - Attach the nozzle adapter with hose from the filling port to the filling/drain valve.
 - and place the other end of the hose into a suitable collective vessel. There are approx. 15 l coolant in the cooling circuit.
 - Open the filling/drain valve. Residual quantities may remain in the cooling circuit.
2. Fill in new coolant.
- Required coolant: ANTIFROGEN N, SPINNER BN 39463A (20 l canister)
- Hold hose upwards and insert a funnel.
- 
- Fill in new coolant until it is visible in the reservoir.
3. Deaerate the cooling circuit, refer to chapter 8.2.
4. Correct the coolant level, refer to chapter 8.4.
5. Finishing:
- Close filling/drain valve.
 - Remove hose.
 - Screw on rear cover.
 - Screw on cap of filling port.
 - Connect hose to cap.

9 Warranty

Do not disassemble the SmartLoad. The warranty is void, if the SmartLoad is modified, improperly handled or third party intervention or modification has occurred or the maintenance procedure and intervals were not properly followed.

10 Repairs

Troubleshooting and repairs must be only carried out by qualified technical personnel or an instructed person under the direction and supervision of qualified personnel (refer to chapter 1.4 "Qualifications of personnel"). The safety instructions and in particular chapter 1. "Safety" of this product manual must be observed.



Do not open components to avoid the risk of electric shock and personal injury.

Electrically skilled persons may replace tripped mains fuses, check the PLC display, or reset triggered motor protection switches integrated in the inverters:

- If the green and red indicator lamps do not lite up although mains is connected and the main switch is turned on, check the mains inlet fuses. Unplug the mains connector at the back of the control cabinet to get access to the fuses. Turn the fuse holder to the left and pull it out. Replace the tripped fuses size 5x 20 mm:
250 V AC, 10 A T (time-lag)
- To check the PLC display, open the control box of the SmartLoad and make sure that the date and time are set correctly and that there are no error messages. Details are given in the attached PLC manual 10058594.
- If the motor protection of the inverter VFD1 or VFD2 has tripped: Turn off the main switch, wait about 30 seconds and then turn on power again.

11 Demounting



Before you start, ensure to read and understand the section safety messages and in particular chapter 1 "Safety" of this product manual. Only electrically skilled persons may demount SPINNER SmartLoads in accordance with the national safety and accident prevention regulations.

Failure to observe could result in death or serious injury.



WARNING

Electric shock hazard

Electric shock can cause severe burns and fatal injuries.

Before you start ensure to disconnect your entire system from the power supply. Utilize appropriate devices and methods to prevent accidental energizing.



WARNING

Radio Frequency Hazard

Radio Frequency Power can cause burns, eye injuries and electrical shock.

Before you start ensure to disconnect your entire system from the power supply. Utilize appropriate devices and methods to prevent accidental energizing.



CAUTION

Hot surface

The resistor elements heat up during normal operation and may cause burns.

Do not remove any covers shortly after use of the SmartLoad.

Do not touch the resistor elements before cooled down.



WARNING

Crushing Hazard

Falling objects may cause death and serious injury.

The SmartLoad is heavy. Use suitable lifting gear and the lifting lugs of the SmartLoad only. The lifting gear must be approved to carry at least 160 kg. Do not lift the SmartLoad at the RF connector.

Safety shoes are required. If it is necessary to stand below the SmartLoad during installation, safety shoes and hardhat are required.

Disconnect in the following order:

- Interlock loop connectors
- Mains cable
- RF connection
- Separate PE conductor

12 Disposal



CAUTION

Poisoning Hazard

Skin or eye contact may cause irritation. Inhaling may irritate the respiratory organs.

Avoid skin or eye contact. Do not inhale gases, fumes and aerosols.

Observe the attached safety data sheet M36457 of the coolant.



Wear safety gloves



Wear eye protection

Empty the cooling circuit, refer to section 1 in chapter 8.5.

NOTICE Residual quantities remain in the cooling circuit.

The user is responsible for disposing of the SmartLoad in accordance with the national waste disposal regulations. Improper disassembly or disposal may be hazardous.

Observe the material data sheet of the coolant.

Please contact SPINNER in advance, before returning the SmartLoad for disposal.

13 Spare Parts

Designation	Order-No.	Qty.
Power cord with IEC 60320-1 C19 socket	BN A77310	1
Interlock cable connector	BN 102964	1
ANTIFROGEN N coolant 39% glycol, 20l	BN 39463A	1

14 Contacts

SPINNER GmbH • Headquarters

Erzgiessereistr. 33
80335 München

Germany

tel.: +49 89 12601-0
info@spinner-group.com
www.spinner-group.com

SPINNER Telecommunication Devices Co., Ltd.

351 Lian Yang Road
Songjiang Industrial Zone
Shanghai
201613 P.R. **China**

tel.: +86 21 577 45377
info-china@spinner-group.com