

Multi Channel Rotary Joint || BN 532348

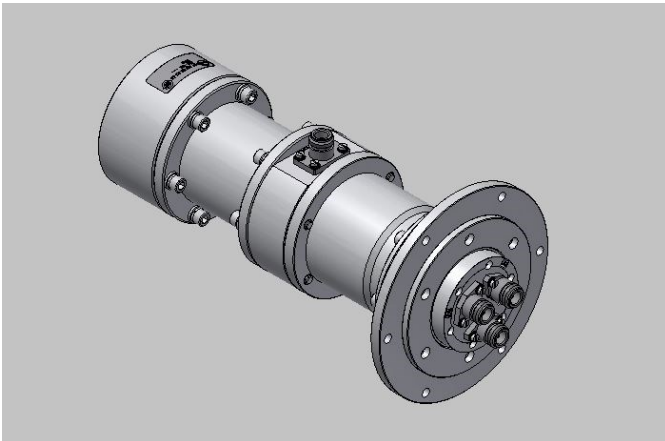

Annex: 532348-0E  
 Product manual: M36018  
 Application note: TD-00021

**Radio frequency channel characteristics**

Channel designation	Channel 1	Channel 2	Channel 3
Interface type / material / surface finish	N-f (50 Ω) / stainless steel / passivated	N-f (50 Ω) / stainless steel / passivated	N-f (50 Ω) / stainless steel / passivated
Frequency range	1.0 to 1.1 GHz	1.0 to 1.1 GHz	1.0 to 1.1 GHz
Peak power capability	10 kW	10kW	10kW
Average power capability	300 W	50 W	50 W
VSWR, max.	1.2	1.2	1.2
VSWR variation over rotation, max.	0.05	0.05	0.05
Insertion loss, max.	0.5 dB	0.5 dB	0.5 dB
Insertion loss variation over rotation, max.	0.05 dB	0.05 dB	0.05 dB
Phase variation over rotation, max.	2.5 deg.	2.5 deg.	2.5 deg.
Phase tracking over rotation, max.	2 deg.		
Isolation, min. / typ.	50 dB / 60 dB	50 dB / 60dB	50 dB / 60 dB

Multi Channel Rotary Joint || BN 532348

**Mechanical data**

Rotating speed, max.	60 rpm
Life, min.	120 x 10 <sup>6</sup> revolutions
MTBF, min.	100000 h
Torque (room / min. temperature), max.	1 Nm / 5 Nm @ start-up 1 Nm / 5 Nm @ rotation
Interface loads, max.	no loads allowed
Case material	aluminum alloy, sea water resistant
Case surface finish	chromate conversion coat per MIL-DTL-5541 type 1 or type 2
Weight, approx.	8 kg
Marking	adhesive label

**Environmental conditions**

<b>Operation</b>	
Application	ground, fixed
Ambient temperature range	-40 °C to +70 °C
Relative humidity, max.	95% (non-condensing)
Absolute pressure, min.	0.067 MPa (approx. 3660 m above sea level)
Fungus	MIL-STD-810G, method 508.6
Salt fog	Standard exposure of 48h per MIL-STD-810G
<b>Storage</b>	
Ambient temperature range	-50 °C to +70 °C
Relative humidity, max.	95% (non-condensing)
Absolute pressure, min.	0.023 MPa (approx. 15000 m above sea level)
Shock	30 g / 11 ms half sine, 3 shocks in each direction of 3 orthogonal axes.
Vibration	a) from 2 to 10 Hz, 25.4 mm peak to peak, 3 axes, 1 Hz / minute from 2 to 10 to 2 Hz b) from 10 to 200 Hz, 3.5 g peak, 3 axes, 10 Hz / minute from 10 to 200 to 10 Hz
Acceleration	30 g, in each direction of 3 orthogonal axes.
Fungus	MIL-STD-810G, method 508.6

**Further remarks**

No environmental test will be performed. A CoC for guarantee will only be issued, when customer performs all of these tests at his side and at his own expenses