

50 kW SmartLoad || BN 546430C0220

Coaxial load with intelligent control:

- Standby function
- Pump and fan activated only when needed
- Super fast self protection
- Interlock signal
- Single phase power supply
- Rear and side walls can be covered
- Outdoor heat exchanger
- Pressurized cooling circuit



Indoor load unit

Outdoor heat exchanger

Operating modes

Standby and RF power approx. 80 W	natural cooling without pump or fan *
RF power approx. 80 W to approx. 800 W	pump only *
RF power approx. 800 W to 50 kW	pump and fan *

* Depending on the ambient temperature and the RF power applied, the pump and/or fan can switch on at any time and switch off again according to the required cooling capacity.

Radio frequency characteristics

Interface type	6 1/8" EIA (50 Ω) per IEC 60339-2, facing upwards
Frequency range	DC to 790 MHz
Average power rating, max.	50 kW
Proof voltage, max.	17 kV
VSWR, max.	1.04 @ DC to 108 MHz or 1.04 @ 108 to 470 MHz or 1.04 @ 470 to 790 MHz or 1.08 @ DC to 790 MHz

Cooling Aggregate

Mains supply:	Mains voltage Mains frequency Real power consumption Nominal current, max.	187 to 264 V, L, N, PE (or L+, L-, Ground) 50 / 60 Hz 50 W (standby), 3.1 kW (full operation) 15.5 A	
Mains panel connector		male power socket, acc. IEC 60320-1 (C20)	
Interlock loop connection		two-pole connector with screwlocking acc. IEC 60130-9, Co. Binder, series 581/680/682, TYP 09-0303-00-02, or at termination block inside control box	
Interlock loop contact load		SELV per IEC 60950-1 max. 42.4 V AC _{pk} / 60 V DC max. 1 A	
Heat exchanger		50 kW special SPINNER single ventilator type	
Noise level, approx.		Indoor load unit 65 dB (A) @ 1 m distance	Outdoor heat exchanger 48 dB (A) @ 10 m distance
Product Manual		M36541	
Maximum distance indoor unit / heat exchanger		25 m	
Max. height difference indoor unit / heat exchanger		3.5 m	
Pressure of cooling system		0.75 to 1.1 bar	
Weight, approx.		340 kg	

SPINNER GmbH | This document is proprietary to us. All rights reserved. Any use, transfer, or reproduction of this document or the know-how contained therein requires our express consent.

Template TD-00003G

50 kW SmartLoad || BN 546430C0220

Environmental conditions

Operation		
Operational environment	operating sites with limited access	
Ambient temperature range	Indoor load unit -10 to +45°C	Outdoor heat exchanger -20 to +45°C
Relative humidity, max.	95% (non-condensing)	
Altitude, max.	2286 m	
IP protection level	Indoor load unit IP20 per EN 60529	Outdoor heat exchanger IP55 per EN 60529 (suitable for salt water environments)
Storage and transport		
Ambient temperature range	-20 to +70°C	
Relative humidity, max.	95% (non-condensing)	

Coolant

Capacity of cooling circuit, approx.	45 litres (dummy load supplied in unfilled state)
Chemical composition, brand	mixture of distilled water, 39 Vol. % ethylene glycol and corrosion inhibitor, ANTIFROGEN N
Density (temperature sensitive)	1.054 kg/dm ³ @ +20°C

Scope of delivery and accessories

Scope of delivery	dummy load indoor unit outdoor heat exchanger with 25 m hard-wired cable power cord with IEC 60320-1 C19 socket (pigtail) interlock cable connector product manual material safety data sheet of the coolant 50 m hose to connect indoor unit to outdoor heat exchanger 4 pcs automatic vents 60 litres coolant 1 set of clamps, etc. to connect hoses	
Spare parts	power cord with IEC 60320-1 C19 socket (pigtail) interlock cable connector coolant 30 litres canister ANTIFROGEN N 39% glycol automatic vent	BN A77310 BN 102964 BN A74423 BN B29689
Accessories	filling pump set 230 V AC, 50 Hz filling pump set 115 V AC, 60 Hz wall hanger support set	BN 155890C0000 BN 155890C0001 BN A76789C0001

This document is proprietary to us. All rights reserved. Any use, transfer, or reproduction of this document or the know-how contained therein requires our express consent.

SPINNER GmbH
 Template TD-00003G

50 kW SmartLoad || BN 546430C0220

Outline (all dimensions in millimeter)

Indoor load unit

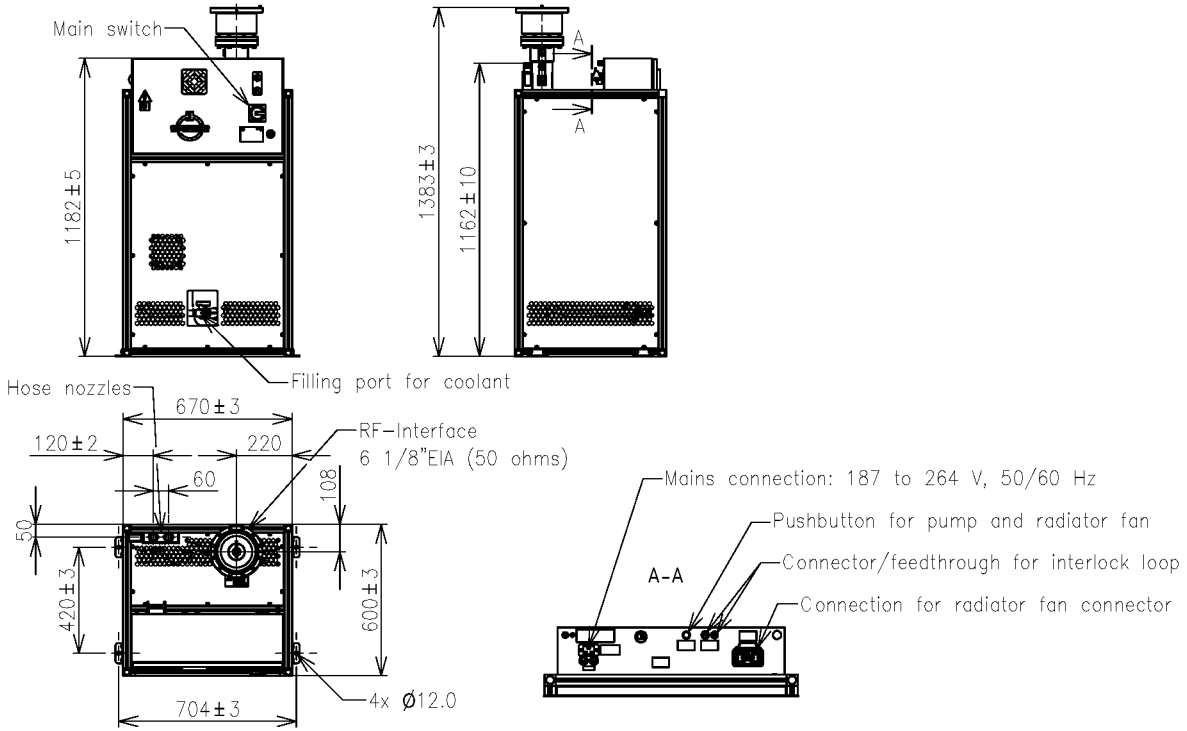

Outdoor heat exchanger

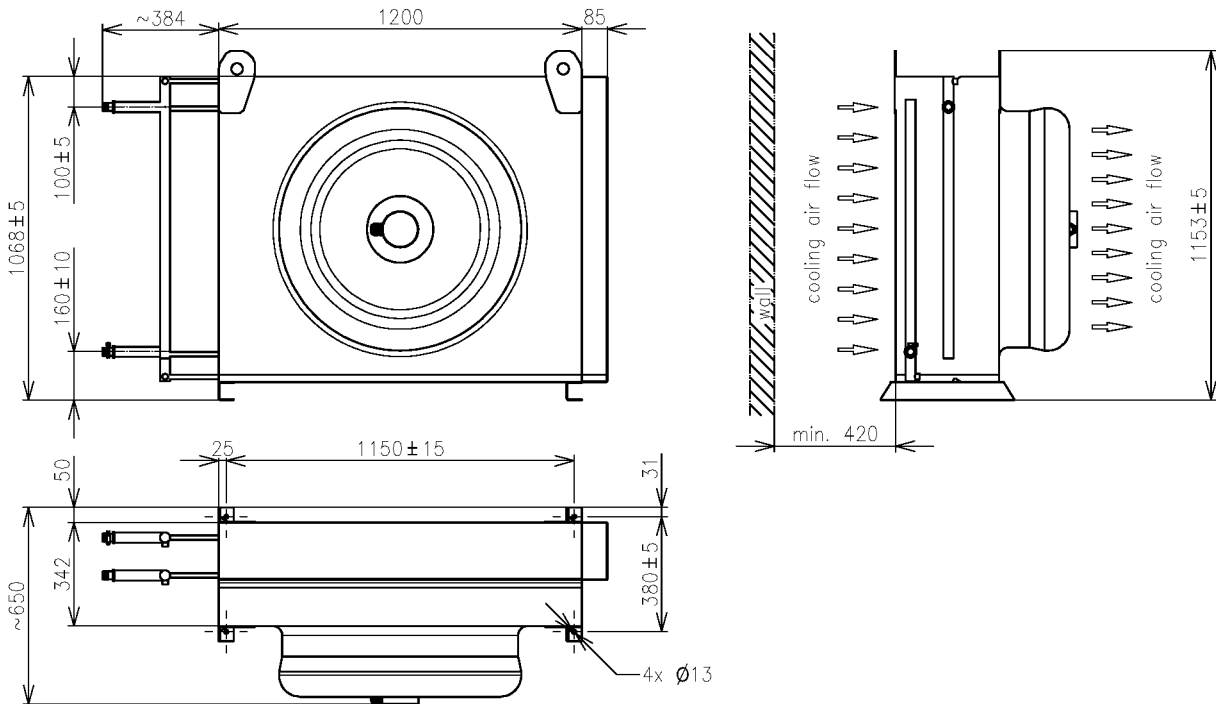

SPINNER GmbH
 This document is proprietary to us.
 All rights reserved. Any use, transfer, or reproduction of this document
 or the know-how contained therein requires our express consent.

Template TD-00003G