

Coaxial 2-Way-Splitter

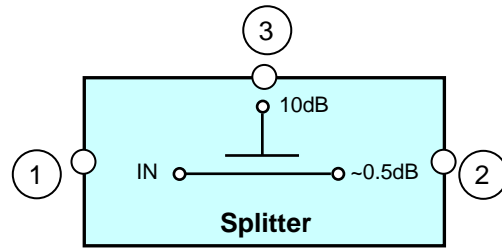

Picture not binding



block diagram

Electrical characteristics

Part number	BN 818245	BN 818345	BN 923045
Splitting ratio	1 : 0.1 : 0.9		
Frequency range	Range 1 Range 2 Range 3	170-380 MHz 380-1500 MHz 1710-2700 MHz	
Insertion loss	~ 0.5 dB (Main line)		
Coupling	10 dB -1/+1.5 dB		
VSWR	≤ 1.2 (Port 1.2) *		
Passive intermodulation (IM3), 3rd order 2 x 20W	≤ -155 dBc typical: ≤ -160dBc	≤ -160 dBc typical: ≤ -165dBc	≤ -150 dBc typical: ≤ -155dBc
Impedance	50 Ohm		
Power Rating	500 W CW (5 kW peak / 20µs)		250 W CW (5 kW peak / 20µs)

* According to DIN 14024-1

Mechanical characteristics

Connectors	7-16 female	4.3-10 female	N female
Dimensions, approx. (Without brackets and connectors)	See drawing		
Paint color	N/A		
Weight, approx.	0.55 kg		
Wall / Mast mounting	to be ordered separately under BN B09499		

Environmental conditions

Class. of environmental conditions	ETSI EN 300019-1-1 Class 1.2 ETSI EN 300019-1-2 Class 2.3 ETSI EN 300019-1-4 Class 4.1E
Degree of protection	IP 68
Operation Ambient temperature range	-20 °C to +55 °C
Storage Ambient temperature range	-40 °C to +85 °C
Relative humidity, max.	95% (non-condensing)

SPINNER GmbH
 This document is proprietary to us.
 All rights reserved. Any use, transfer, or reproduction of this document
 or the know-how contained therein requires our express consent.

Template TD-00002Y

Coaxial 2-Way-Splitter

Outline (all dimensions in millimeter)

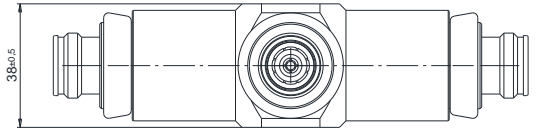
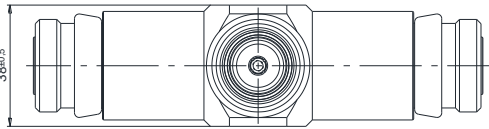
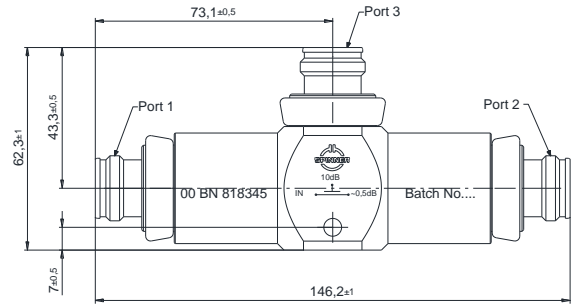
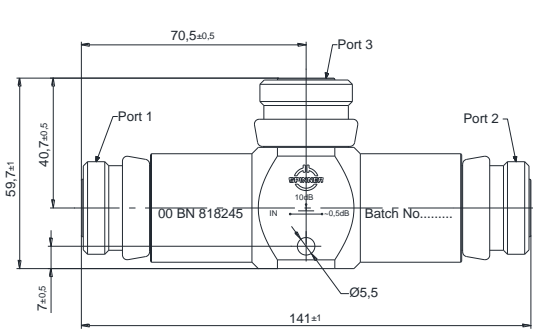

modifications reserved

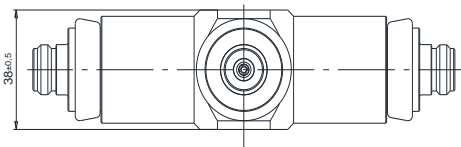
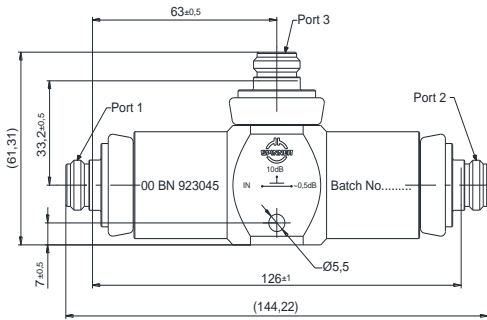

modifications reserved

SPINNER GmbH
 This document is proprietary to us.
 All rights reserved. Any use, transfer, or reproduction of this document
 or the know-how contained therein requires our express consent.

Template TD-00002Y

Coaxial 2-Way-Splitter

Measurements:

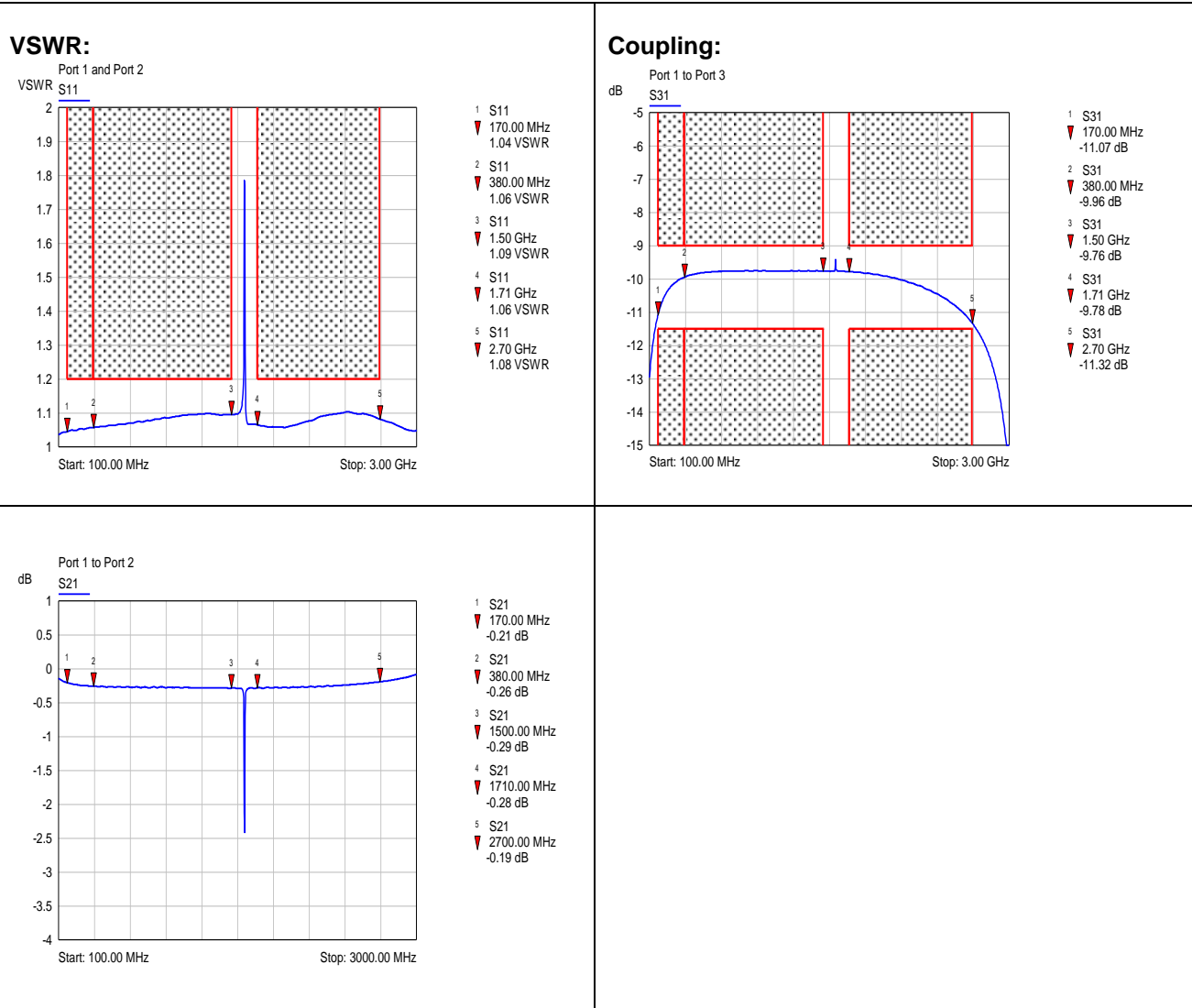

Signal splitting ratios (approximate values, for information only):

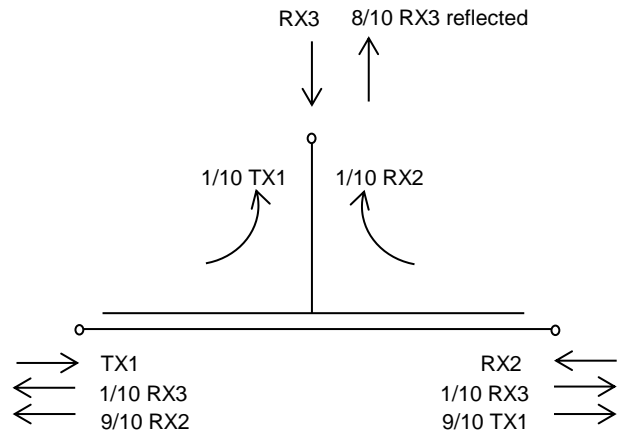
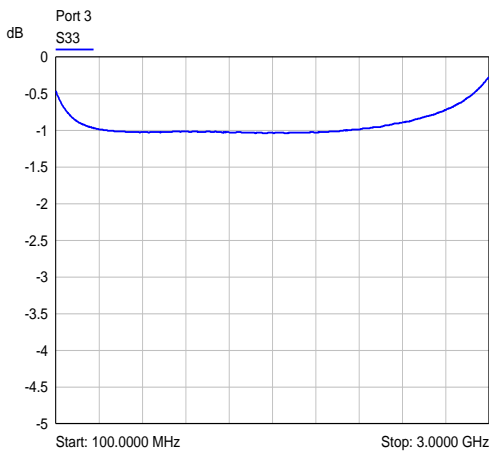

SPINNER GmbH
 This document is proprietary to us.
 All rights reserved. Any use, transfer, or reproduction of this document
 or the know-how contained therein requires our express consent.

Template TD-00002Y