

Single Channel Rotary Joint || BN 835078

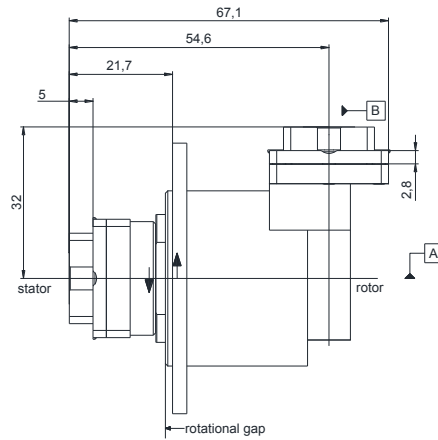
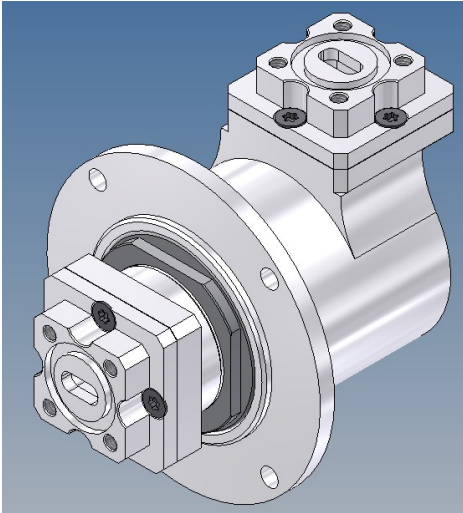

all dimensions in millimeter

Outline and dimensions as per drawing: 835078-0E Issue A  
 Product manual: n/a  
 Application note: TD-00021

**Radio frequency characteristics**

Channel designation	Channel 1
Interface type / material / surface finish	PBR320 (IEC154) (modified, fully compatible to IEC154-PBR-320) with threaded holes M3 Aluminum alloy / chromated
Interface orientation	Style L
Frequency range	27.5 to 31.0 GHz
Peak power capability	1 kW (operating altitude if not pressurized, max. 2000 m) 60 W (operating altitude if not pressurized, max. 11000 m)
Average power capability	100 W
VSWR, max.	1.3
VSWR variation over rotation, max.	0.15
Insertion loss, max.	0.30 dB
Insertion loss variation over rotation, max.	0.15 dB

Single Channel Rotary Joint || BN 835078

**Mechanical data**

Rotating speed, max.	300 rpm
Life, min.	200 x 10 <sup>6</sup> revolutions
Torque (room / min. temperature), max.	0.1 / 0.2 Nm
Interface loads, max.	± 5 N in axial direction ± 5 N in radial direction
Case material	Aluminum alloy, sea water resistant
Case surface finish	Chromate conversion coat per MIL-DTL-5541
IP protection level	IP40 per EN 60529
Weight, approx.	0.25 kg
Marking	Laser engraving

**Environmental conditions**

<b>Operation</b>	
Application	Ground, fixed or ground, mobile
Ambient temperature range	-40 to +71 °C
Relative humidity, max.	95% (non-condensing)
<b>Storage</b>	
Ambient temperature range	-55 to +85 °C
Relative humidity, max.	95% (non-condensing)