

MIMO X-Pol Panel Antenna, 698MHz-2700MHz

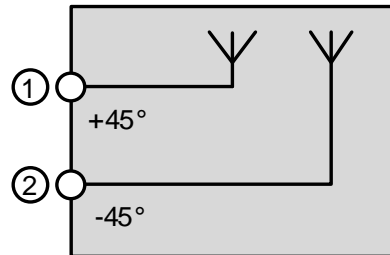

not binding



block diagram

| Part number                               | BN A77136                |         |           |           |           |           |
|---|--------------------------|---------|-----------|-----------|-----------|-----------|
| Connector                                 | 2 x 4.3-10 female (50 Ω) |         |           |           |           |           |
| Frequency range, [MHz]                    | 698-806                  | 806-960 | 1710-1880 | 1920-2170 | 2200-2500 | 2490-2700 |
| Gain, [dBi]                               | 6.4                      | 7.5     | 8.1       | 8.1       | 8.1       | 7.1       |
| Polarization, [deg]                       | +45 / -45                |         |           |           |           |           |
| Beam width, [deg]                         | Horizontal               | 61-82   |           | 63-87     |           |           |
|   | Vertical                 | 55-80   |           | 55-85     |           |           |
| Front-To-Back Ratio, [dB]                 | ≥ 10                     |         | ≥ 15      |           |           |           |
| VSWR                                      | ≤ 1.5                    |         |           |           |           |           |
| Isolation, [dB]                           | > 20                     |         | > 23      |           |           |           |
| Intermodulation (IM3)<br>@ 2x 20 W, [dBc] | ≤ -150                   |         |           |           |           |           |
| Input power, [W]                          | max. 50                  |         |           |           |           |           |
| Degree of protection                      | Indoor / IP54            |         |           |           |           |           |
| Weight, without Mounting Kit, [kg]        | 0.88                     |         |           |           |           |           |
| Radome Material and Color                 | ABS, White, RAL9003      |         |           |           |           |           |
| Temperature range, [°C]                   | -55 – +60                |         |           |           |           |           |
| Dimensions (H x W x D), [mm]              | 308 x 190 x 82           |         |           |           |           |           |
| Operational Humidity                      | < 95%                    |         |           |           |           |           |
| RoHS                                      | Compliant                |         |           |           |           |           |
| Flammability rating                       | UL 94-V0                 |         |           |           |           |           |
| Mounting Kit                              | On-wall                  |         |           |           |           |           |

**Radiation pattern:**

**Horizontal  
pattern**

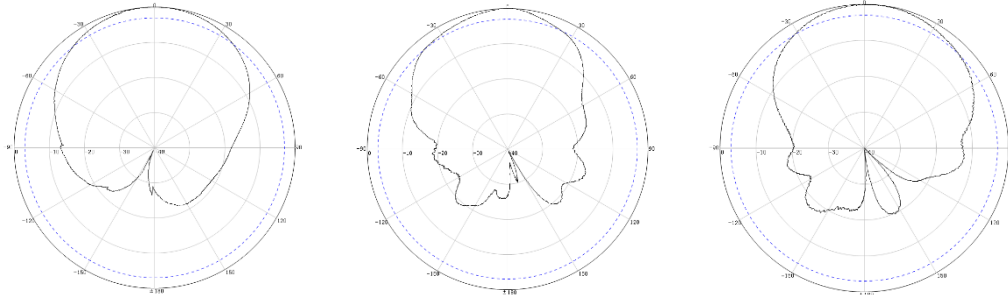

**Vertical  
pattern**

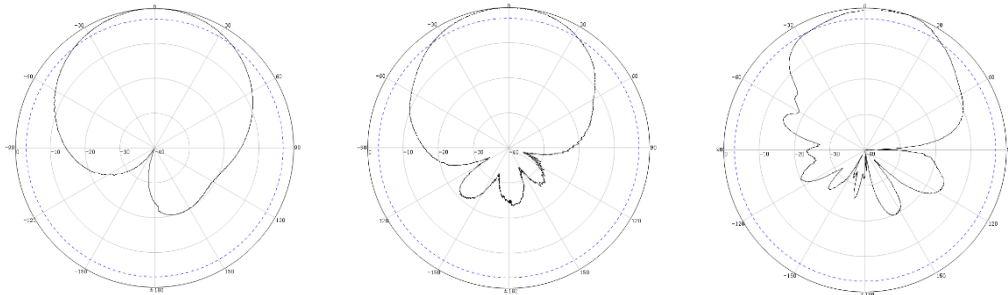

900MHz

1710MHz

2500MHz

**Dimensions and mounting:**

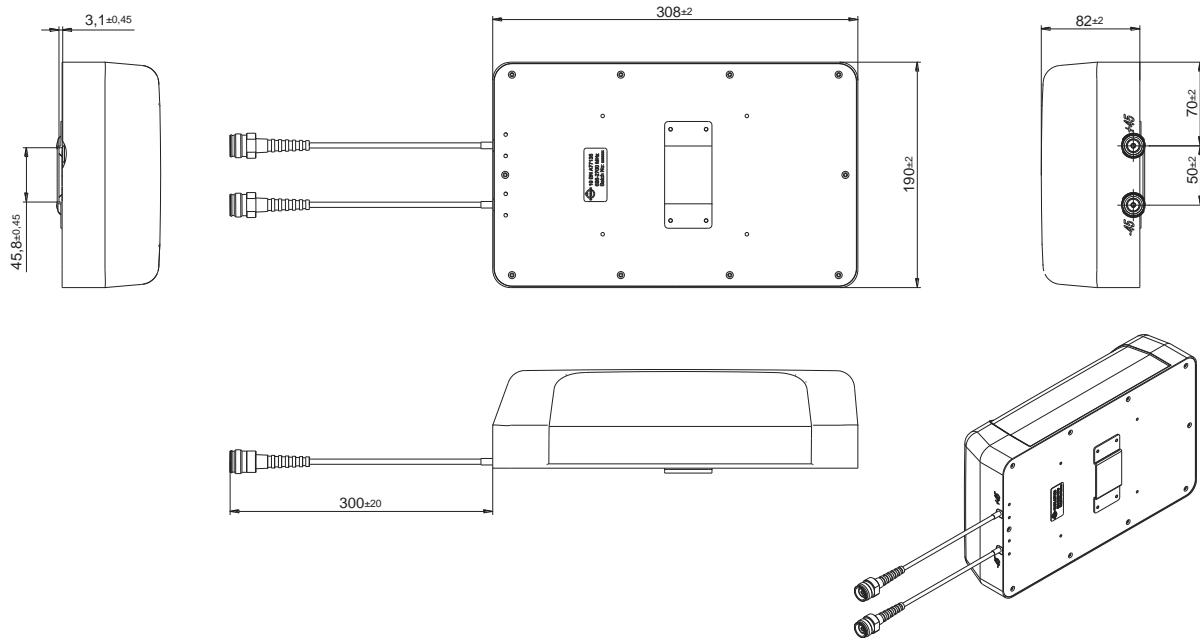

**Standard:**

4.3-10 female (50 ohms): IEC 61169-54

Subject to change without notice

**Mounting kit:**

